



# GALLI & CASSINA

*Plus Valves*

SINCE 1919



## LUBRICATED



## PLUG

## VALVES

## STANDARD & FULL

## JACKETED

## TYPE





## Galli&Cassina Profile



**Galli&Cassina** is a prominent Italian Company, leader in Design and manufacturing a complete range of Lubricated Plug valves.

The company is located in Solaro near to Milan (Italy)

**Galli&Cassina** was founded in 1919, and it is one of the oldest Italian companies which today is still in the valve business; in the beginnings G&C business activity was concentrated in the production of valves to serve the domestic growing market.

After the first ten years the company gradually turned its production towards the newly born Chemical Industry.

**G&C** was the first in Italy to produce valves in stainless steel and other special material in light with the demand

of the most important chemical companies.

It was not possible to expand further the Milan factory which was built in 1930 and enlarged after the second world war, for this reason in 1991 **Galli&Cassina** has moved to a new location in Solaro (Milan) with modern building and facilities.

After 30 years of experience in chemical valves, **Galli&Cassina** started the production of Plug Valves to serve the Oil & Gas worldwide market becoming one of the most significant supplier for all



with extensive offices and workshop covering 12.000 sq.mt. area including 5000 sq.mt. of covered space.



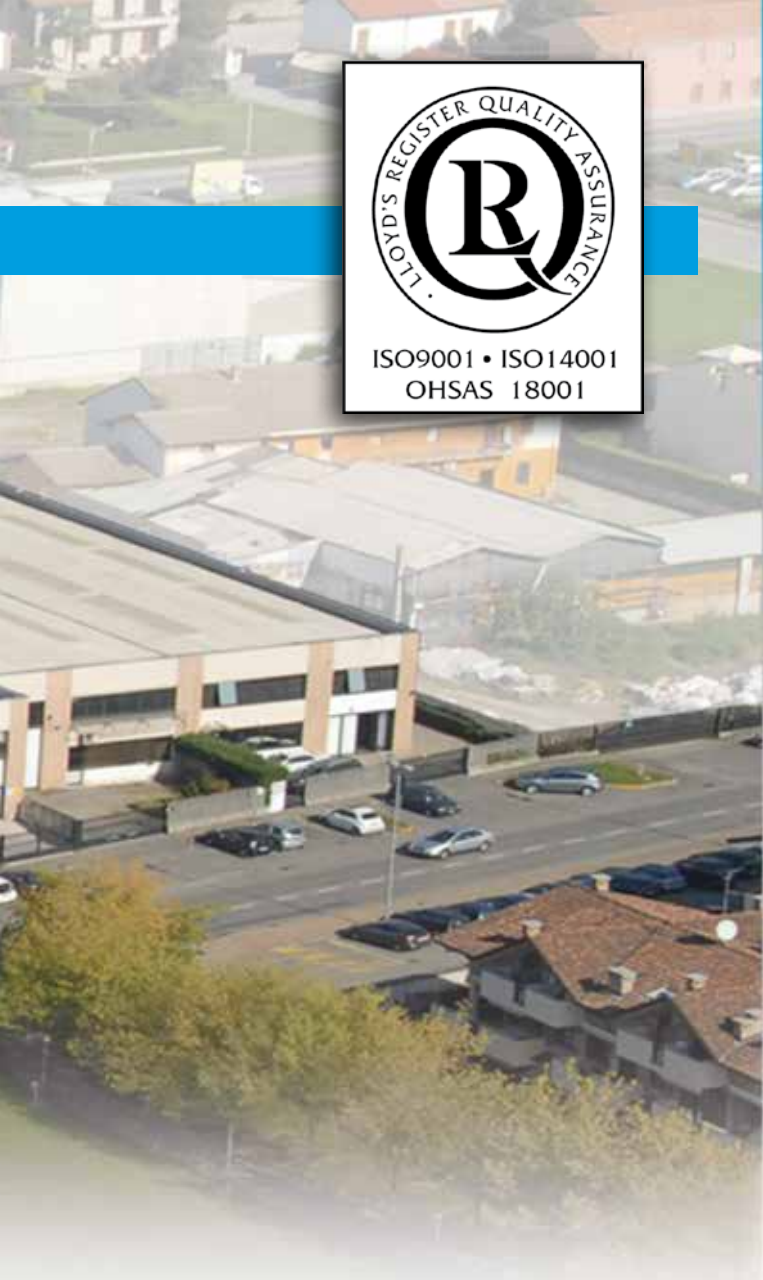

**1. WORKSHOP & OFFICES.**



**2. WELDING.**



**3. MATERIAL RECEIVING.**



**4. TESTING AND INSPECTION.**



**5. PACKING AND SHIPPING.**



**6. WAREHOUSE.**

*International Oil & Gas companies across the world.*

*Its sales activity covers most of the continents with a leading and growing presence in Europe, Middle East, North & South America and Far East resulting in a sales and service network with subsidiaries, branch offices and distributors, achieving the reputation of high quality and reliable product.*

*Galli&Cassina pays a particular attention to company development in every area, to be in line with the continuous market evolution.*

*The proved technical, production, and financial*

*capabilities combined with experience of human resources are the result of Galli&Cassina reputation all over in the world.*

*Galli&Cassina's Quality Assurance System & HSE according to ISO 9001-2008, ISO 14001 & ISO 18001 have been assessed, approved and certified by Lloyd's Register, while the API 6D and 6A monogram have been certified by API*

*(American Petroleum Institute) - Washington U.S.A. Nowadays Galli&Cassina is*

*proud to celebrate its 95 years presence in the world valves market.*



*Plus Valves*





# Galli&Cassina Profile



1

2

3

4

6

5



# Index



## Section 1

Page 8

Two Way Standard Type  
ANSI 125-150-300 Lb.  
DIN PN 16-40.

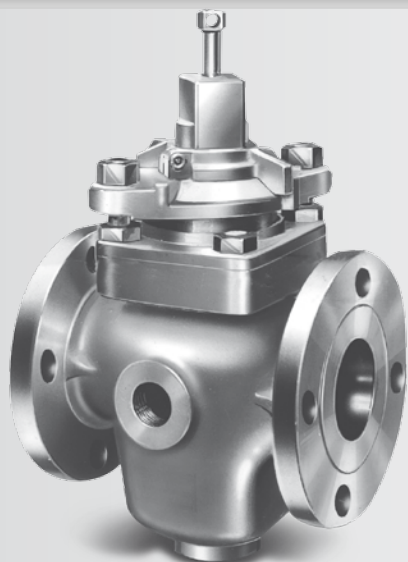

## Section 2

Page 20

Two Way Jacketed  
ANSI 150-300 Lb.

Two Way Full Jacketed  
ANSI 150-300 Lb.

DIN PN 16-40 (Flanges only)



## Section 3

Page 32

Multiport Three-Four Way  
ANSI 150-300 Lb.  
DIN PN 16-40 (Flanges only)  
(Transflow/Non Transflow Pattern).

Multiport Three-Four Way  
Jacketed  
Full Jacketed  
ANSI 150 Lb.  
DIN PN 16-40 (Flanges only)



# Index

Class					Page N.	Figure
<b>Section 1 Two Way Plug Valves Standard Type</b>						
ANSI 125	Short Pattern	1"	to	8"	10	SCC - X1R
ANSI 125	Short Pattern	6"	to	12"	11	SCR - X1R
ANSI 125	Regular Pattern	1/2"	to	8"	12	SRC - X1T/RC - 1R
ANSI 125	Regular / Venturi Pattern	6"	to	12"	13	SRR - X1R/VR - 1R
ANSI 150	Short Pattern	1"	to	8"	14	SCC - 01F/SCC - 01R
ANSI 150	Short Pattern	6"	to	12"	15	SCR - 01R
ANSI 150	Regular Pattern	1"	to	8"	16	SRC - 01F/SRC - 01R
ANSI 150	Regular / Venturi Pattern	6"	to	12"	17	SRR - 01R/SVR - 01R
ANSI 300	Short Pattern	1/2"	to	6"	18	SCC - 03F/SCC - 03R
ANSI 300	Short Pattern	5"	to	12"	19	SCR - 03R
<b>Section 2 Two Way Jacketed</b>						
ANSI 150	Short Pattern	2"	to	6"	21	VCC - 01R
ANSI 150	Short Pattern	6"	to	12"	22	VCR - 01R
ANSI 150	Regular Pattern	1 1/2"	to	6"	23	VRC - 01R/VRR - 01R
ANSI 300	Short Pattern	1 1/2"	to	6"	24	VCC - 03R
ANSI 300	Venturi Pattern	6"	to	12"	25	VVR - 03R
<b>Two Way Full Jacketed</b>						
ANSI 150	Short Pattern	1" x 2"	to	8" x 10"	26	ZRC - 01R
ANSI 150	Regular Pattern	10" x 12"	to	24" x 26"	27	ZRR - 01R
ANSI 300	Regular Pattern	1" x 2"	to	8" x 10"	28	ZRC - 03R
ANSI 300	Regular Pattern	10" x 12"	to	24" x 26"	29	ZRR - 03R
<b>Two Way Full Jacketed - Full Bore</b>						
ANSI 150	Full Bore	1" x 2"	to	10" x 12"	30	ZFC - 01R/ZFR - 01R
ANSI 300	Full Bore	1" x 2"	to	10" x 12"	31	ZFC - 03R/ZFR - 03R
<b>Section 3 Multiport Three-Four Way Valves</b>						
ANSI 150	Long Pattern	1/2"	to	5"	32	MCR - LRC - URC - 01T/01R
ANSI 150	Long Pattern	4"	to	8"	34	MRR - LRR - URR - 01T/01R
ANSI 300	Long Pattern	1/2"	to	4"	35	MRC - LRC - URC - 03T/03R
ANSI 300	Long Pattern	4"	to	8"	36	MRC - LRC - URC - 03T/03R

## Engineering Data - page 39 to 40

**Note: Galli&Cassina** with the scope of improving continuously his products, reserve the right to change or modify without incurring in any obligation to provide or

install such modification on plug valves previously or subsequently sold.





# Patterns

**Galli & Cassina Plug Valves are available in four different patterns. The pattern indicates basic information about the valve in terms of end to end dimension (according to API 6D & BS 5353) and the size of the flow port through the valve.**

## Short Pattern

Short Pattern Valves have compact face to face dimensions (like a Gate Valve) and rectangular port areas of 40% to 60% of a Full Bore Plug valve. This provides an economical valve for services where some reduction of flow rates can be tolerated. The Short Pattern is only in classes 150 and 300.

## Venturi Pattern

Venturi Pattern Plug Valves also have a longer face to face but with a rectangular port areas of 40-50% of a Full Bore Plug valve. These are typically used on services where flow rate is not critical. The long lead into and out of the port minimises pressure drop when the valve is fully opened.

## Regular Pattern

Regular Pattern Plug Valves have a longer face to face dimensions and rectangular port areas of 50-70% of a Full Bore Plug valve. This configuration provides minimal loss of flow while economising on the overall valve dimensions.

## Full Bore

Full Bore Plug Valves have long face to face dimensions and a round port that is not smaller than specified in Annex A of ASME B 16.34 or/and API 6D. This configuration provides unrestricted flow and allows the passage of pigs and spheres through the valve. It is also preferred for highly abrasive conditions as it minimises pressure drop and erosion in the valve.

# Applicable-Standards-Specification

**Lubricated plug valves are designed to use with most refining services according to API 599 or BS 5353 norms whichever is applicable. API 6D norm aims to standardize the materials as well as instructions to manufacture valves suitable for energy transportation in the pipelines.**

API 6D	Specification for pipeline valves	BS 1504	Specification for steel casting for pressure purposes
API 6FA	Specification for fire test for valves	BS 2080	Face to face - Centre to face - End to end Steel valves
API 598	Valve inspection and testing	BS 5353	Specification for steel plug valves
API 599	Steel plug valves flanged or butt welding ends	BS 6755 part 1	Testing of valves (Spec. for production pressure testing requirements)
ASME/ANSI B 16.5	Pipe flanges and flanged fittings	BS 6755 part 2	Testing of valves (Spec. for fire safe - Testing requirements)
ASME/ANSI B 16.10	Face-to-face and end-to-end dimensions of valves	CSA-Z 245-15	Canadian Std Association
ASME/ANSI B 16.25	Buttwelding ends	MSS-SP6	Standard finish for contact face of pipe flanges
ASME/ANSI B 16.34	Valves-flanged, threaded and welding ends	MSS-SP25	Standard marking system for valves
ASME/ANSI B 31.3	Chemical plant and petroleum refinery piping	MSS-SP44	Steel pipeline flanges
ASME/ANSI B 31.4	Liquid transportation system for liquid petroleum gas	MSS-SP55	Quality standard for steel casting visual method
ASME/ANSI B 31.8	Gas transmission and distribution piping system	MSS-SP61	Pressure Testing of Steel valves
ANSI B 1.20.1	Pipe - Threads	MSS-SP78	Cast Iron Plug Valve Flanged and Threaded Ends
ASTM	American society for testing and materials	NACE Std. MR 01.75 Latest Edition	National association of corrosion engineers



## Standard Type

**Standard type plug valves are made in accordance with the conventional bolted type gland valves, with extended operating stem integral with the longer side of the tapered plug.**

**In this type of valve, the plug is kept in the body by a bolted cover which centres the plug in the body avoiding the blowout of it, without the gland.**

**Gland function, is to keep the pressure on packing rings which prevents any possibility of leakage through the shank and at the same time it guarantees the weatherseal.**

**Furthermore, the pressure is transmitted to the plug through the shim, so the plug can maintain its correct position in the body.**

**Shim function, is to reduce the friction between the packing**

**rings with the longer side of the tapered plug, besides avoiding shank fluid infiltration.**

**The lubrication of the plug can be done any time when it is necessary to guarantee the tightness of the valve, even when the valve is in service.**

**The above operation shall be made simply by injecting lubricant through the lubricant screw, where a check valve prevents leakage of grease during injection.**

**From the internal sealant duct, the grease goes down through the grooves which then serve to lubricate the plug.**

**During valve rotation, open/close or reverse, each groove is insulated from the rest of lubricant system, thus avoiding any possibility of lubricant leakage into the line.**

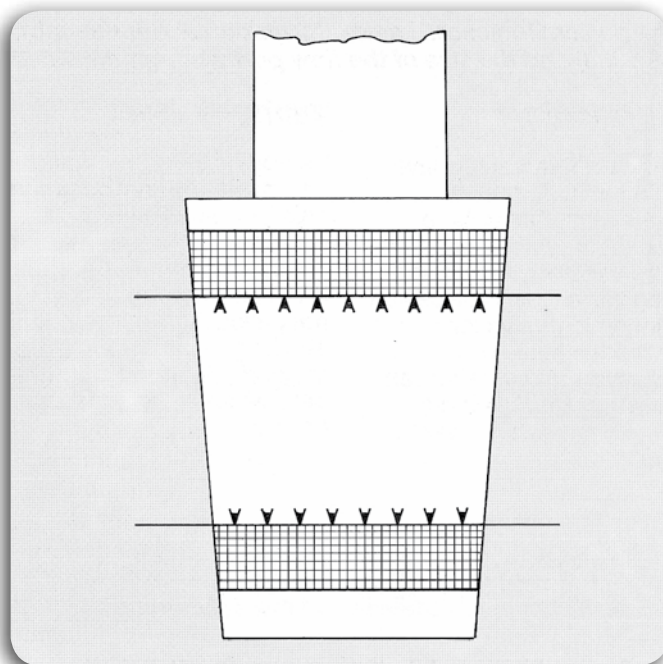

### Special Treatment

Special antifriction treatment with PTFE of the plug, provides at the same time the following advantages:

- Greatly improved wear resistance.
- Low friction between plug and body.
- Low torque moment and resistance to seizure.

## Fire Safe Test



**All Galli & Cassina's plug valves have been tested against fire resistance, according to API - 6FA and BS 6755 - Part. 2 standards and witnessed by international third party. Metal to Metal seating surfaces, as well as the stem sealing compound with graphite guarantee a high reliability performance of our plug valves while are in exposure to fire test conditions.**





## Section 1 - Two Way Standard Type - Design Features

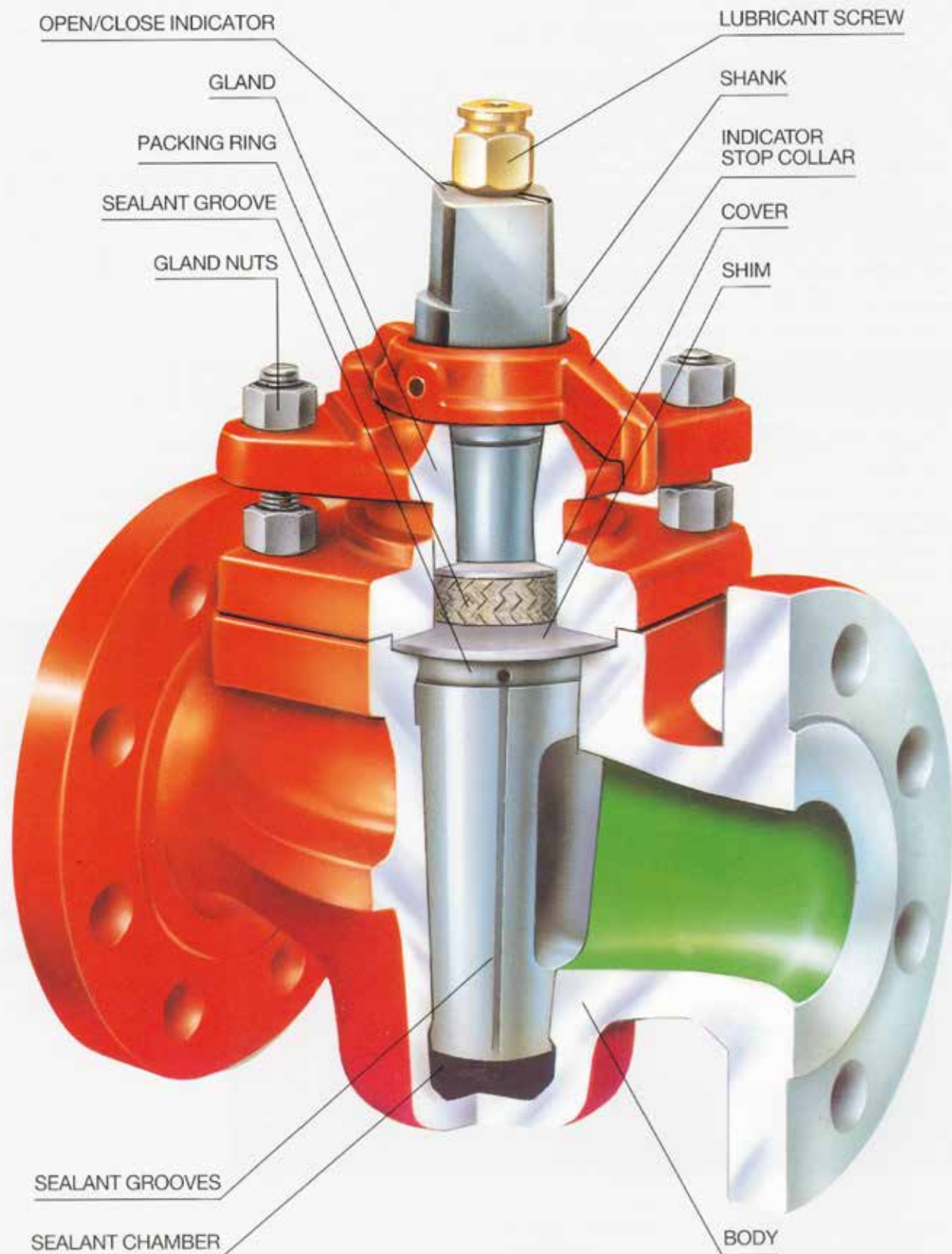

**NOTE:** Each valve with wrench operation, the plug open and closed position are assured by corresponding stop indicator fitted on bare stem. The open position of the valve has the stop indicator parallel to flow direction of the fluid.



# Material Selection Guide for GALLI&CASSINA Valves

In the table shown below there are designated N. 3 categories of trim materials, suitable for many different service conditions.

1. Standard Carbon Steel Body and Plug - API 6D. (ASTM-A105-A216 WCB/WCC material) suitable for general services.
2. Carbon Steel Body and Plug (A352 LCB/LCC material) suitable for low temperature services.

3. Carbon Steel Body and Plug (ASTM A216WCB/WCC material) suitable for "SOUR SERVICE" (H<sub>2</sub>S and CO<sub>2</sub>) according to NACE-MR.01.75/Latest Edition.

**Note:** Other material upon request.

## Standard design categories (Typical construction materials)

Trim Service	Class	• Body • Cover	Plug / Stem	Bolting
<b>1 Standard service</b> Natural gas Hydrocarbons	150 to 300	ASTM A105 ASTM A216 WCB/WCC	ASTM A105 ASTM A216 WCB/WCC PTFE Treatment	ASTM A193-B7 ASTM A194-2H
<b>2 Low temperature</b> Natural gas Hydrocarbons	150 to 300	ASTM A350-LF2 ASTM A352 LCB/LCC Max C 0.23%	ASTM A350-LF2 ASTM A352- LCB/LCC PTFE Treatment	ASTM A320-L7 ASTM A194 Gr.7
<b>3 Sour Service</b> (H <sub>2</sub> S and CO <sub>2</sub> ) Hydrocarbons	150 to 300	ASTM A105 Max 187 HB ASTM-A216 WCB/WCC Max 22HRC PTFE Treatment	ASTM A105 Max 187 HB ASTM-A216 WCB/WCC Max 22HRC PTFE Treatment	ASTM A193-B7M ASTM A194-2HM PTFE Treatment 237 HB





# ANSI Class 125 (PN 10)

(Cast Iron Body and Plug) ASTM - A - 126 - Gr.B

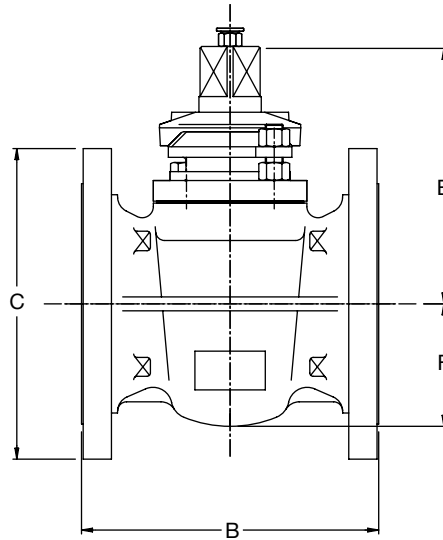

SCC X1R - Short with Wrench

Size	NPS DN	Short Pattern									
		1 25	1½ 40	2 50	2½ 65	3 80	4 100	5 125	6 150	8 200	
FACE TO FACE	<b>B</b>	mm	140	165	178	191	203	229	254	267	292
FLANGE DIAMETER ANSI 125 FF	<b>C</b>	mm	108	127	152	178	191	229	254	279	343
N. TAPPED HOLES UNC THREADED IN FLANGES			-	-	-	-	-	-	2	2	2
CENTER LINE TO TOP OF STEM	<b>E</b>	mm	107	136	152	176	207	230	245	300	330
CENTER LINE TO BOTTOM OF BODY	<b>F</b>	mm	42	62	67	76	100	110	130	160	180
WEIGHT		kg	6	11	13	19	25	38	60	78	100
WRENCH - LENGHT		mm	235	320	320	400	500	570	720	1010	1230



# ANSI Class 125 (PN 10)

(Cast Iron Body and Plug) ASTM - A - 126 - Gr.B

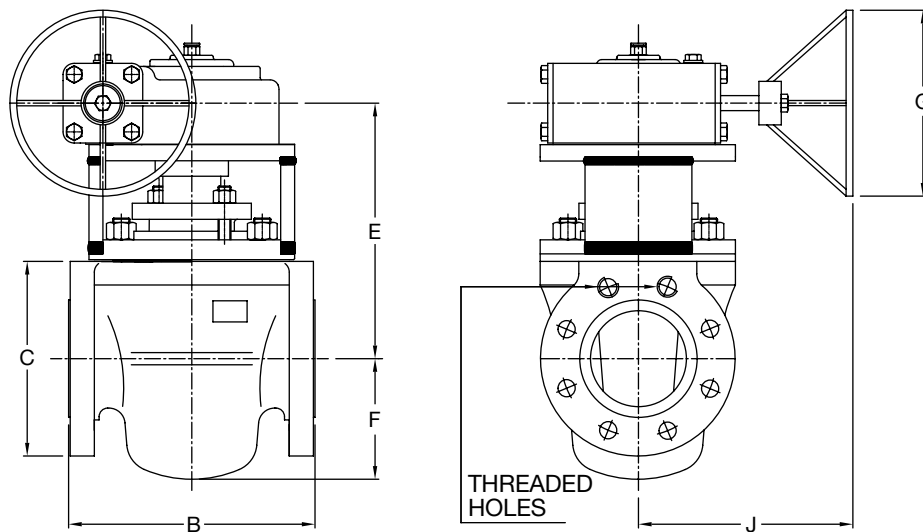

SCR - X1R - Short with Gear

Size	NPS DN	Short Pattern				
		6 150	8 200	10 250	12 300	
FACE TO FACE	<b>B</b>	mm	267	292	330	356
FLANGE DIAMETER ANSI 125 FF	<b>C</b>	mm	279	343	406	483
N. TAPPED HOLES UNC THREADED IN FLANGES			2	2	2	4
CENTER LINE TO CENTER OF HANDWHEEL	<b>E</b>	mm	570	600	660	700
CENTER LINE TO BOTTOM OF BODY	<b>F</b>	mm	160	180	220	286
HANDWHEEL DIAMETER	<b>G</b>	mm	560	560	560	560
LONGITUDINAL CENTER LINE TO FACE HANDWHEEL	<b>J</b>	mm	330	330	450	450
WEIGHT		kg	115	140	180	280





# ANSI Class 125 (PN 10)

(Cast Iron Body and Plug) ASTM - A - 126 - Gr.B

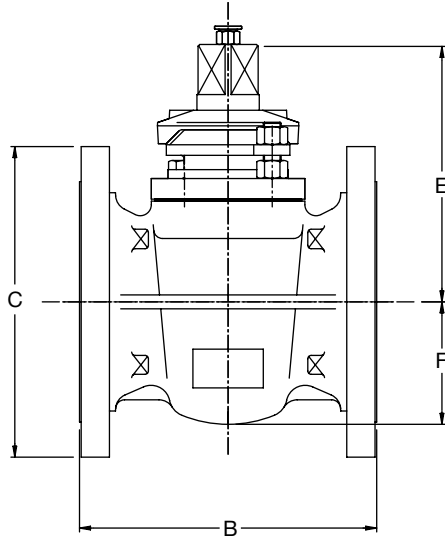

**SRC X1R - Regular with Wrench**

Size	NPS DN	Regular Pattern												
		1/2 15	3/4 20	1 25	1 1/4 32	1 1/2 40	2 50	2 1/2 65	3 80	4 100	5 125	6 150	8 200	
END TO END THREADED	<b>A</b>	mm	90	95	110	130	135	150	175	200	275	-	-	-
FACE TO FACE	<b>B</b>	mm	110	120	140	150	165	200	220	240	305	356	394	457
FLANGE DIAMETER ANSI 125 FF	<b>C</b>	mm	-	-	108	117	127	152	178	191	229	254	279	343
CENTER LINE TO TOP OF STEM	<b>E</b>	mm	92	115	120	140	152	176	207	230	245	296	330	410
CENTER LINE TO BOTTOM OF BODY	<b>F</b>	mm	35	46	50	60	65	76	93	108	130	155	185	230
WEIGHT THREADED ENDS		kg	1,7	3	4	6	7	12	16	24	41	-	-	-
WEIGHT FLANGED		kg	3	4	6	8	10	14	20	27	40	62	80	110
WRENCH - LENGHT		mm	235	235	235	320	320	400	500	570	720	1010	1010	1230



# ANSI Class 125 (PN 10)

(Cast Iron Body and Plug) ASTM - A - 126 - Gr.B

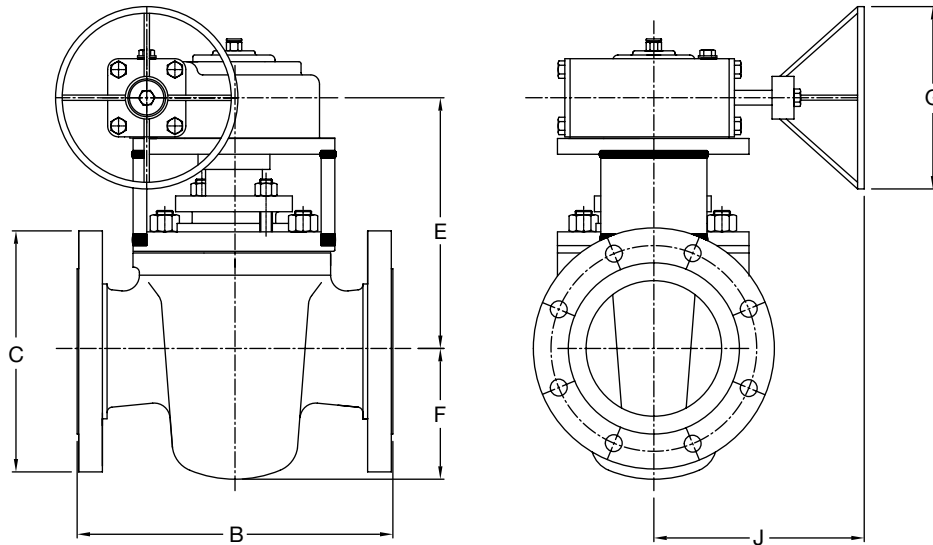

**SRR X1R - Regular with Gear**  
**SVR X1R - Venturi with Gear**

Size	NPS DN	Regular Pattern		Venturi Pattern	
		6 150	8 200	10 250	12 300
FACE TO FACE	<b>B</b> mm	394	457	533	610
FLANGE DIAMETER ANSI 125 FF	<b>C</b> mm	279	343	406	483
CENTER LINE TO CENTER OF HANDWHEEL	<b>E</b> mm	585	690	770	810
CENTER LINE TO BOTTOM OF BODY	<b>F</b> mm	185	230	290	330
DIAMETER	<b>G</b> mm	560	560	560	560
LONGITUDINAL CENTER LINE TO FACE TO HANDWHEEL	<b>J</b> mm	330	330	450	450
WEIGHT	kg	115	146	210	290





# ANSI Class 150 (PN 20)

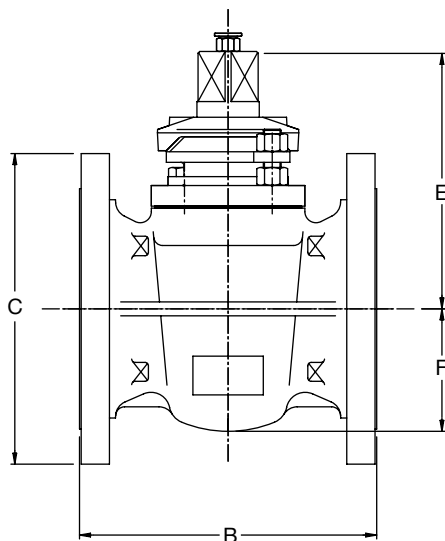

**SCC X1R - Short with Wrench**

Size	NPS DN	Short Pattern									
		1 25	1½ 40	2 50	2½ 65	3 80	4 100	5 125	6 150	8 200	
END TO END THREADED	<b>A</b>	mm	-	-	150	170	180	210	-	-	-
FACE TO FACE	<b>B</b>	mm	140	165	178	191	203	229	254	267	292
FLANGE DIAMETER ANSI 150 RF	<b>C</b>	mm	108	127	152	178	191	229	254	279	343
N. TAPPED HOLES UNC THREADED IN FLANGES			-	-	-	-	-	-	2	2	2
CENTER LINE TO TOP OF STEM	<b>E</b>	mm	107	136	152	176	207	230	245	300	330
CENTER LINE TO BOTTOM OF BODY	<b>F</b>	mm	42	62	67	76	100	110	130	160	180
WEIGHT THREADED ENDS		kg	-	-	9	15	21	31	-	-	-
WEIGHT FLANGED		kg	6	10	14	20	27	40	62	80	110
WRENCH - LENGHT		mm	235	320	320	400	500	570	720	1010	1230



# ANSI Class 150 (PN 20)

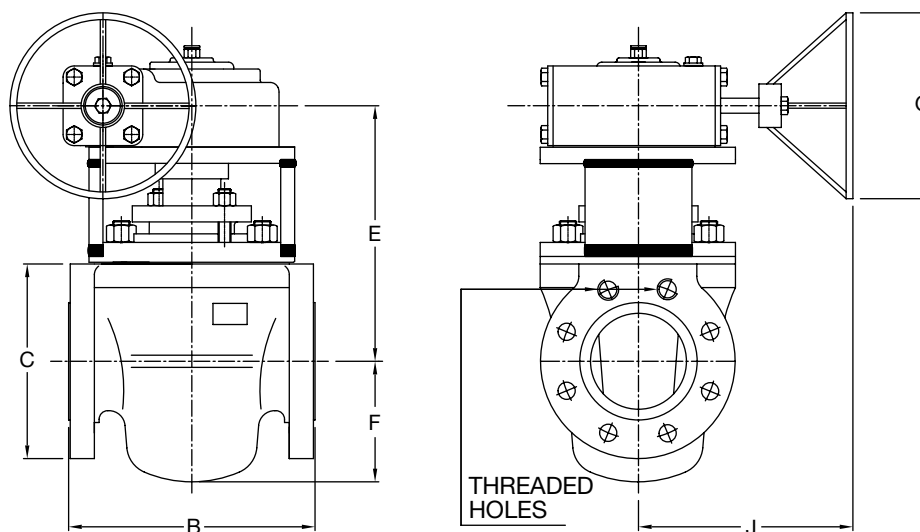

**SCR 01R - Short with Gear**

Size	Short Pattern				
	NPS DN	6 150	8 200	10 250	12 300
FACE TO FACE	<b>B</b> mm	267	292	330	356
FLANGE DIAMETER DIN PN 16	<b>C</b> mm	285	340	405	460
FLANGE DIAMETER ANSI 150	<b>C</b> mm	279	343	406	483
N. TAPPED HOLES UNC THREADED IN FLANGES		2	2	2	4
CENTER LINE TO CENTER OF HANDWHEEL	<b>E</b> mm	570	600	630	690
CENTER LINE TO BOTTOM OF BODY	<b>F</b> mm	160	180	220	286
HANDWHEEL DIAMETER	<b>G</b> mm	560	560	560	560
LONGITUDINAL CENTER LINE TO FACE OF HANDWHEEL	<b>J</b> mm	330	330	450	450
WEIGHT	kg	115	146	210	270





# ANSI Class 150 (PN 20)

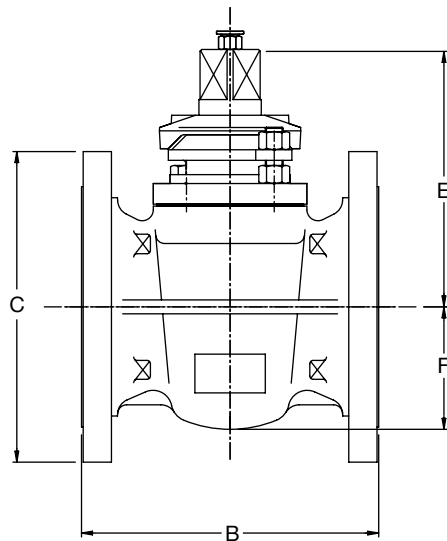

**SRC X1R - Regular with Wrench**

Size	NPS DN	Regular Pattern									
		1 25	1¼ 32	1½ 40	2 50	2½ 65	3 80	4 100	5 125	6 150	8 200
END TO END THREADED	<b>A</b> mm	110	130	135	165	190	205	275	-	-	-
FACE TO FACE	<b>B</b> mm	140	150	165	200	220	240	300	350	394	457
FLANGE DIAMETER DIN PN 16	<b>C</b> mm	115	140	150	165	185	200	220	250	285	340
FLANGE DIAMETER ANSI 150	<b>C</b> mm	108	117	127	152	178	191	229	254	279	343
CENTER LINE TO TOP OF STEM	<b>E</b> mm	120	140	152	176	207	230	245	296	330	410
CENTER LINE TO BOTTOM OF BODY	<b>F</b> mm	42	60	65	80	102	114	133	156	185	230
WEIGHT THREADED ENDS	kg	3,4	7	8	14	18	26	51	-	-	-
WEIGHT FLANGED	kg	6	9	11	19	27	31	55	74	107	175
WRENCH - LENGHT	mm	235	320	320	400	500	570	720	1010	1010	1230



# ANSI Class 150 (PN 20)

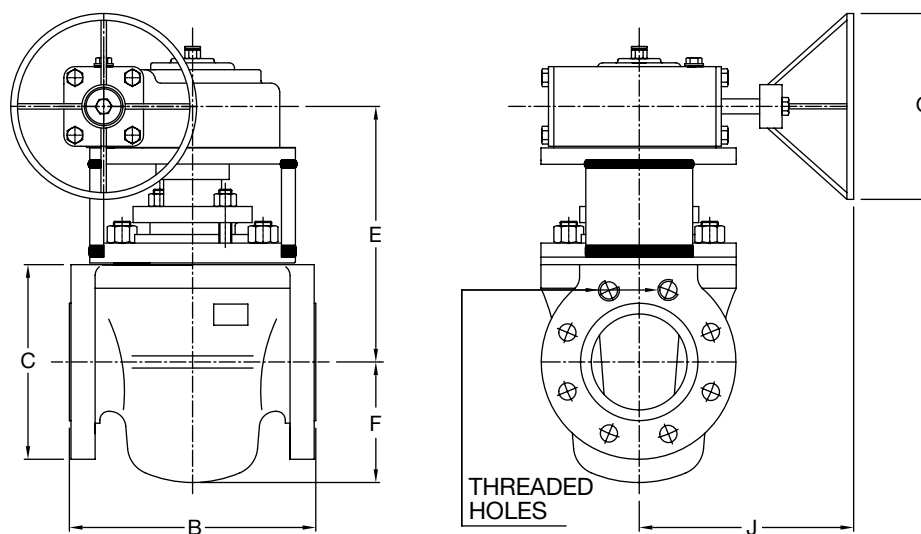

**SRR 01R - Regular with Gear**  
**SVR 01R - Venturi with Gear**

Size	NPS DN	Regular Pattern			Venturi Pattern	
		6 150	8 200	10 250	12 300	
FACE TO FACE	<b>B</b>	mm	394	457	533	610
FLANGE DIAMETER DIN PN 16	<b>C</b>	mm	285	340	405	460
FLANGE DIAMETER ANSI 150	<b>C</b>	mm	279	343	406	483
CENTER LINE TO TOP OF HANDWHEEL	<b>E</b>	mm	585	690	770	810
CENTER LINE TO BOTTOM OF BODY	<b>F</b>	mm	185	230	290	330
HANDWHEEL DIAMETER	<b>G</b>	mm	560	560	560	560
LONGITUDINAL CENTER LINE TO FACE OF HANDWHEEL	<b>J</b>	mm	330	330	450	450
WEIGHT		kg	135	215	240	280



# ANSI Class 300 (PN 50)

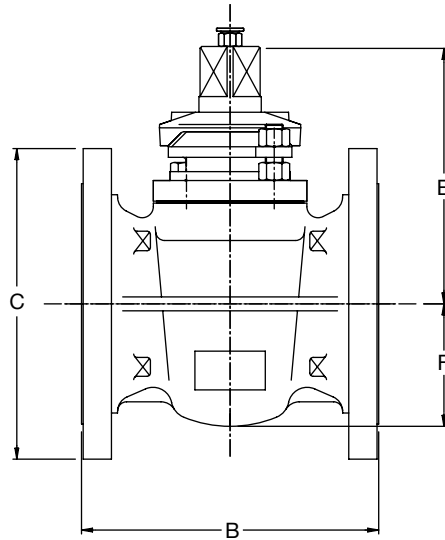

**SCC X1R - Short with Wrench**

Size	NPS DN	Short Pattern										
		1/2 15	3/4 20	1 25	1 1/4 32	1 1/2 40	2 50	2 1/2 65	3 80	4 100	5 125	6 150
END TO END THREADED	<b>A</b> mm	90	95	110	130	135	165	190	205	275	-	-
FACE TO FACE	<b>B</b> mm	130	150	159	-	190	216	241	283	305	-	403
FLANGE DIAMETER DIN PN 40	<b>C</b> mm	95	105	115	140	150	165	185	200	235	270	300
FLANGE DIAMETER ANSI 300 RF	<b>C</b> mm	95	117	124	-	156	165	191	210	254	279	318
CENTER LINE TO TOP OF STEM	<b>E</b> mm	92	115	120	140	152	176	207	230	245	296	300
CENTER LINE TO BOTTOM OF BODY	<b>F</b> mm	30	38	42	60	68	80	102	114	133	155	160
WEIGHT THREADED ENDS	kg	1,8	3	3,4	7	8	14	18	26	51	-	-
WEIGHT FLANGED	kg	3	4,5	6,5	10	13	20	30	38	69	95	130
WRENCH - LENGHT	mm	235	235	235	320	320	400	500	570	720	1010	1010





# ANSI Class 300 (PN 50)

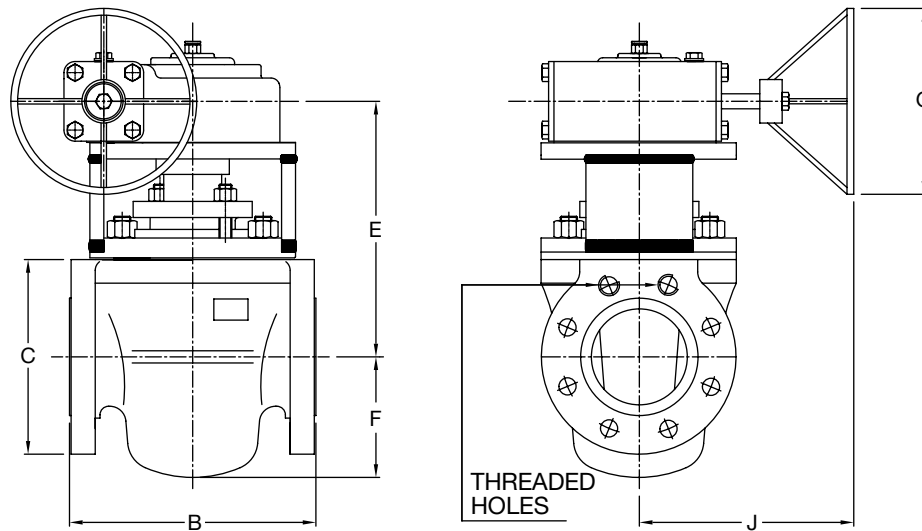

**SCR 03R - Short with Gear**

Size	Short Pattern						
	NPS DN	5 125	6 150	8 200	10 250	12 300	
FACE TO FACE	<b>B</b>	mm	254	403	419	457	502
FLANGE DIAMETER DIN PN 40	<b>C</b>	mm	270	300	375	450	515
FLANGE DIAMETER ANSI 300 RF	<b>C</b>	mm	280	318	381	445	521
CENTER LINE TO CENTER OF HANDWHEEL	<b>E</b>	mm	550	575	600	630	690
CENTER LINE TO BOTTOM OF BODY	<b>F</b>	mm	155	160	194	240	260
HANDWHEEL DIAMETER	<b>G</b>	mm	560	560	560	560	560
LONGITUDINAL CENTER LINE TO FACE OF HANDWHEEL	<b>J</b>	mm	330	330	330	450	450
WEIGHT PN 40		kg	110	145	210	240	320
WEIGHT ANSI 300		kg	118	155	225	255	340



## Section 2 - Two Way Full Jacketed (Oversized Flanges)



## Full Bore Type Jacketed (Oversized Flanges)

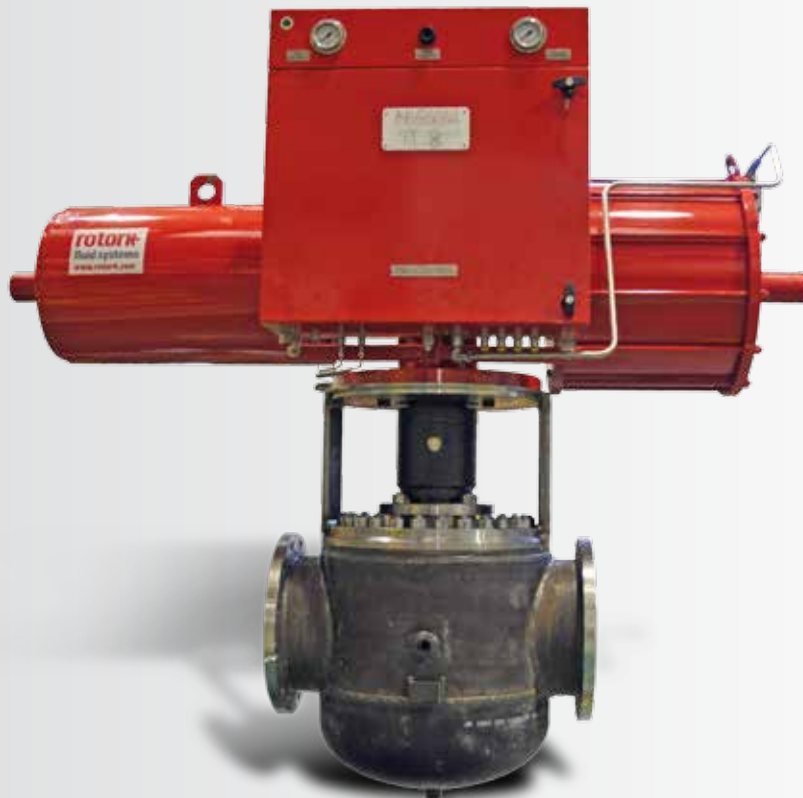



# ANSI Class 150 (PN 20)

## Steam Jacketed Body

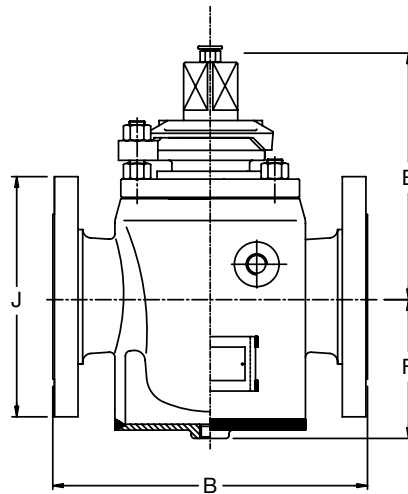

### VCC 01R - Short with Wrench

Size	NPS DN	Short Pattern				
		2 50	2½ 65	3 80	4 100	6 150
FACE TO FACE ANSI 150 RF	<b>B</b> mm	178	191	203	229	267
FLANGE DIAMETER PN 16	<b>C</b> mm	165	185	200	220	285
FLANGE DIAMETER ANSI 150	<b>C</b> mm	152	178	191	229	279
N. TAPPED HOLES UNC THREADED IN FLANGES		-	-	-	-	2
CENTER LINE TO TOP OF STEM	<b>E</b> mm	152	176	207	230	300
CENTER LINE TO BOTTOM OF BODY	<b>F</b> mm	103	115	136	151	210
STEAM/CONDENSATE N. HOLES ¾" N.P.T.	<b>P</b>	3	3	3	3	3
WEIGHT	kg	16	24	31	43	105
WRENCH - LENGHT	mm	320	400	500	570	1010





# ANSI Class 150 (PN 20)

## Steam Jacketed Body

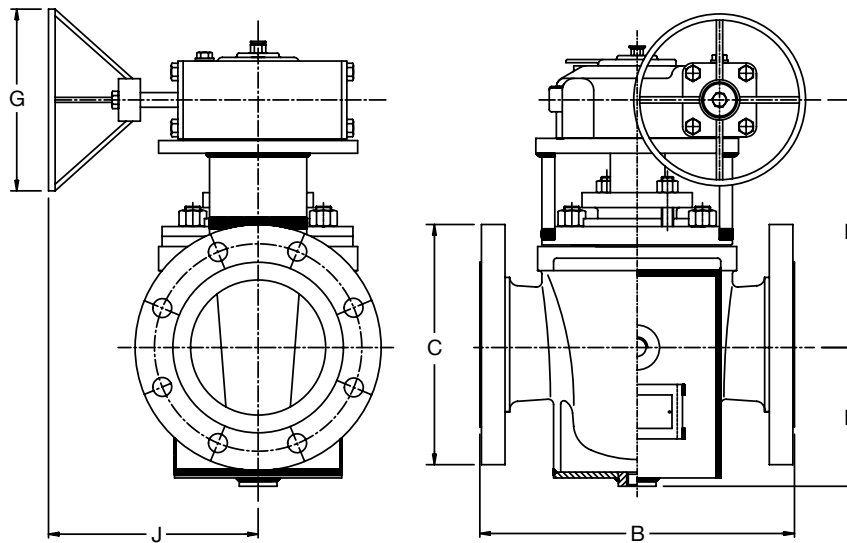

VCR 01R - Short with Gear

Size	NPS DN	Short Pattern			
		6 150	8 200	10 250	12 300
FACE TO FACE	<b>B</b> mm	267	292	330	356
FLANGE DIAMETER DIN PN 16	<b>C</b> mm	285	340	405	460
FLANGE DIAMETER ANSI 150 RF	<b>C</b> mm	279	343	406	483
N. TAPPED HOLES UNC THREADED IN FLANGES		2	2	2	4
CENTER LINE TO CENTER OF HANDWHEEL	<b>E</b> mm	570	600	630	690
CENTER LINE TO BOTTOM OF BODY	<b>F</b> mm	200	235	270	334
HANDWHEEL DIAMETER	<b>G</b> mm	560	560	560	560
LONGITUDINAL CENTER LINE TO FACE OF HANDWHEEL	<b>J</b> mm	330	330	450	450
STEAM/CONDENSATE N. HOLES $\frac{3}{4}$ " N.P.T.	<b>P</b>	3	3	3	3
WEIGHT	kg	140	180	230	325



# ANSI Class 150 (PN 20)

## Steam Jacketed Body

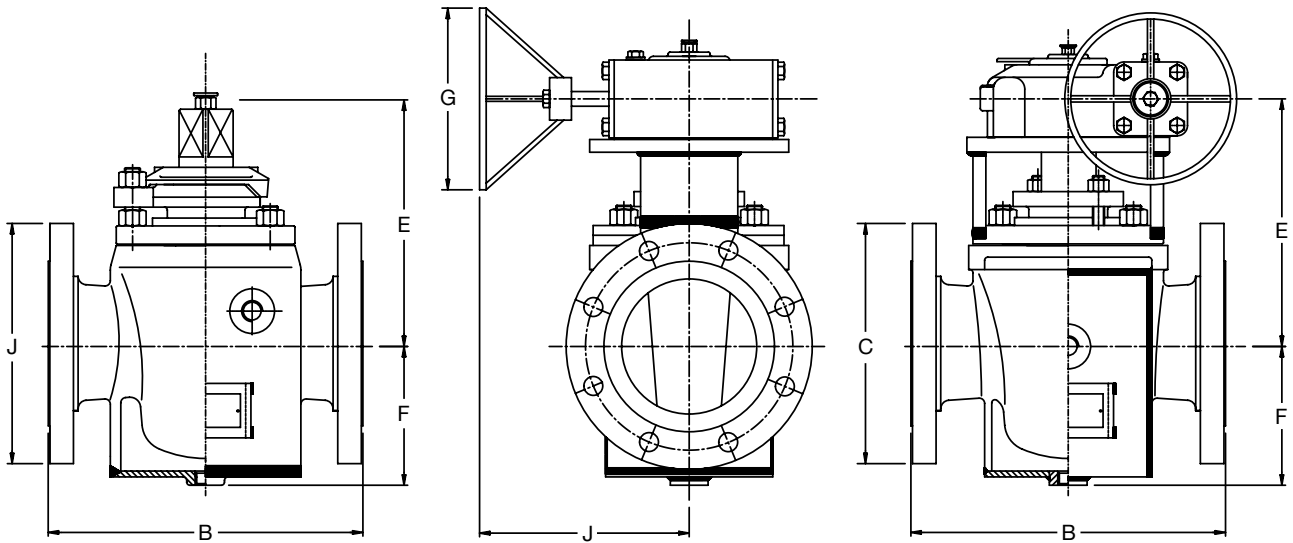

**VRC 01R - Regular with Wrench**

**VRR 01R - Regular with Gear**

Size	NPS DN	Regular Pattern							
		1½ 40	2 50	2½ 65	3 80	4 100	6 150	8 200	
FACE TO FACE	<b>B</b> mm	165	200	220	240	350	450	450	
FLANGE DIAMETER DIN PN 16	<b>C</b> mm	150	165	185	200	220	285	285	
FLANGE DIAMETER ANSI 150	<b>C</b> mm	127	152	178	191	229	279	279	
CENTER LINE TO TOP OF STEM	<b>E</b> mm	156	175	208	230	250	330	-	
CENTER LINE TO CENTER OF HANDWHEEL	<b>E</b> mm	-	-	-	-	-	-	650	
CENTER LINE TO BOTTOM OF BODY	<b>F</b> mm	97	115	130	145	180	245	245	
HANDWHEEL DIAMETER	<b>G</b> mm	-	-	-	-	-	560	560	
LONGITUDINAL CENTER LINE TO FACE OF HANDWHEEL	<b>J</b> mm	-	-	-	-	-	330	330	
STEAM/CONDENSATE N. HOLES ¾" N.P.T.	<b>P</b>	3	3	3	3	3	3	3	
WEIGHT	kg	14	22	30	36	80	154	175	
WRENCH - LENGHT	mm	320	400	500	570	720	-	-	



# ANSI Class 300 (PN 50)

## Steam Jacketed Body

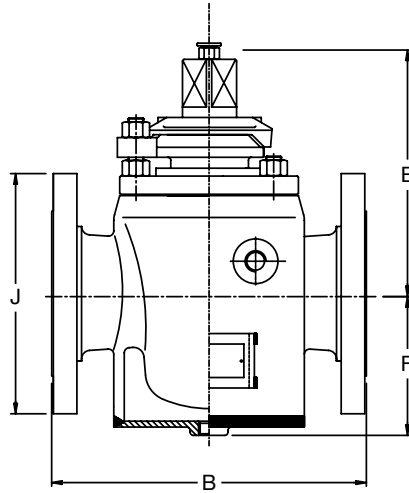

VCC 03R - Short with Wrench

Size	NPS DN	Short Pattern					
		1½ 40	2 50	2½ 65	3 80	4 100	
FACE TO FACE	<b>B</b> mm	190	216	241	283	305	
FLANGE DIAMETER DIN PN 40	<b>C</b> mm	150	165	185	200	235	
FLANGE DIAMETER ANSI 300 RF	<b>C</b> mm	156	165	191	210	254	
CENTER LINE TO TOP OF STEAM	<b>E</b> mm	156	175	208	230	250	
CENTER LINE TO BOTTOM OF BODY	<b>F</b> mm	97	115	130	145	180	
STEAM/CONDENSATE N. HOLES ¾" N.P.T.	<b>P</b>	3	3	3	3	3	
WEIGHT PN 40	kg	14	22	30	36	86	
WEIGHT ANSI 300	kg	17	23	32	42	95	
WRENCH - LENGHT	mm	320	400	500	570	720	



# ANSI Class 300 (PN 50)

## Steam Jacketed Body

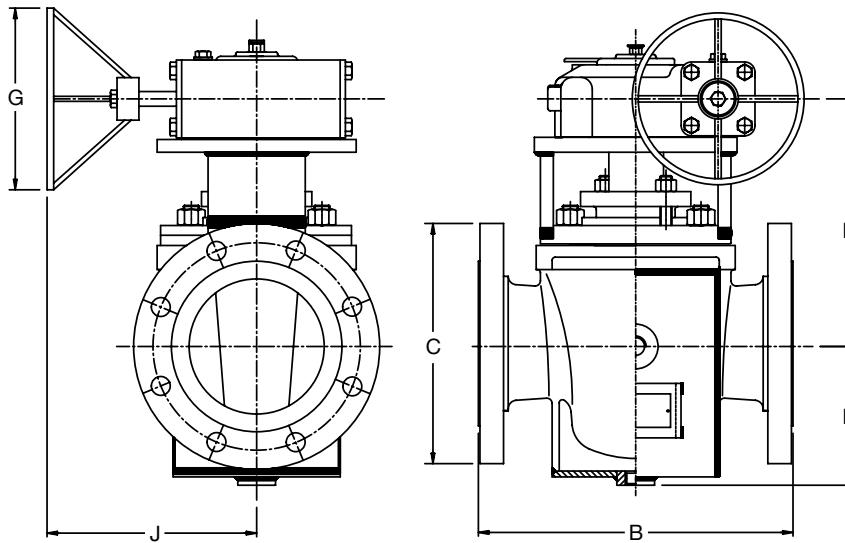

VCR 03R - Regular with Gear

Size	NPS DN	Short Pattern			
		6 150	8 200	10 250	12 300
FACE TO FACE	<b>B</b> mm	403	419	457	502
FLANGE DIAMETER DIN PN 40	<b>C</b> mm	300	375	450	515
FLANGE DIAMETER ANSI 300 RF	<b>C</b> mm	318	381	445	521
CENTER LINE TO TOP OF HANDWHEEL	<b>E</b> mm	575	615	645	700
CENTER LINE TO BOTTOM OF BODY	<b>F</b> mm	220	255	295	310
HANDWHEEL DIAMETER	<b>G</b> mm	560	560	560	560
LONGITUDINAL CENTER LINE TO FACE OF HANDWHEEL	<b>J</b> mm	330	330	450	450
STEAM/CONDENSATE N. HOLES $\frac{3}{4}$ " N.P.T.	<b>P</b>	3	3	33	
WEIGHT PN 40	kg	180	250	320	445
WEIGHT ANSI 300	kg	190	260	330	460





# ANSI Class 150 (PN 20)

## Full Jacketed Body

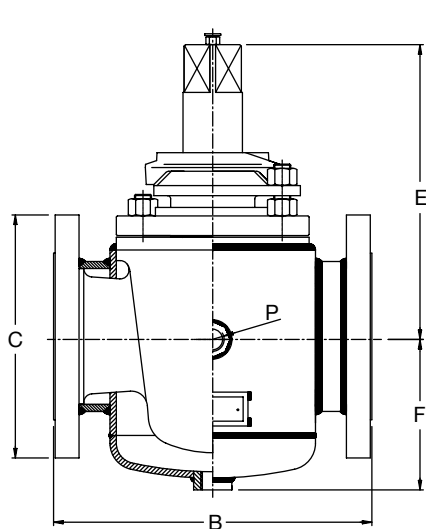

**ZRC 01R - Regular with Wrench**

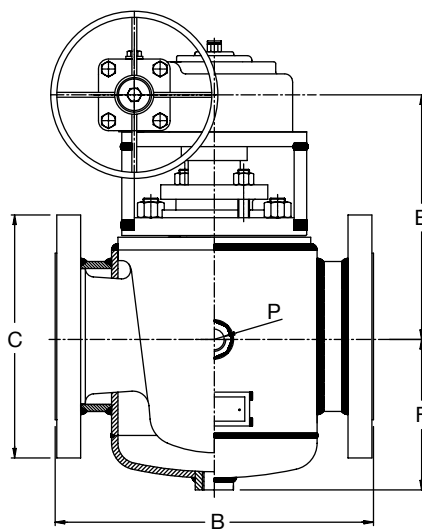

**ZRR 01R - Regular with Gear**

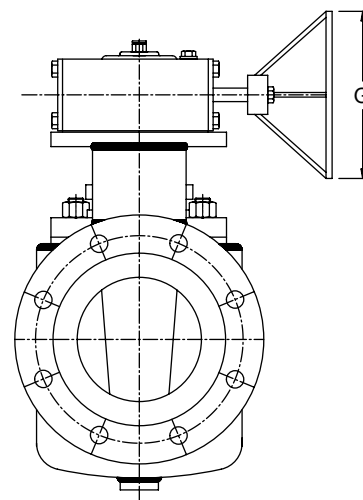

Size	NPS DN	Regular Pattern							
		1x2 25x50	1½ x 2½ 40x65	2x3 50x80	3x4 80x100	4x6 100x150	6x8 150x200	8x10 200x250	
FACE TO FACE	<b>B</b> mm	200	220	240	300	390	419	457	
FLANGE DIAMETER PN 16	<b>C</b> mm	165	185	200	220	285	340	405	
FLANGE DIAMETER ANSI 150	<b>C</b> mm	152	178	191	229	279	343	406	
CENTER LINE TO TOP OF STEM	<b>E</b> mm	120	156	175	230	245	--		
CENTER LINE TO BOTTOM OF BODY	<b>F</b> mm	75	97	115	145	175	220	260	
CENTER LINE TO CENTER OF HANDWHEEL	<b>E</b> mm	-	-	-	-	-	500	615	
HANDWHEEL DIAMETER	mm	-	-	-	-	-	560	560	
STEAM/INLET N. 2 HOLES N.P.T.	<b>P<sub>1</sub> or P</b> in.	½ - ¾	¾ - 1	¾ - 1	¾ - 1	¾ - 1	¾ - 1	¾ - 1	
CONDENSATE OUTLET N. 1 HOLE N.P.T.	<b>P<sub>2</sub></b> in.	¾	1	1	1	1	1	1	
WRENCH - LENGHT	mm	235	320	400	570	720	-	-	
WEIGHT	kg	13	20	27	45	115	210	270	



# ANSI Class 150 (PN 20)

## Full Jacketed Body

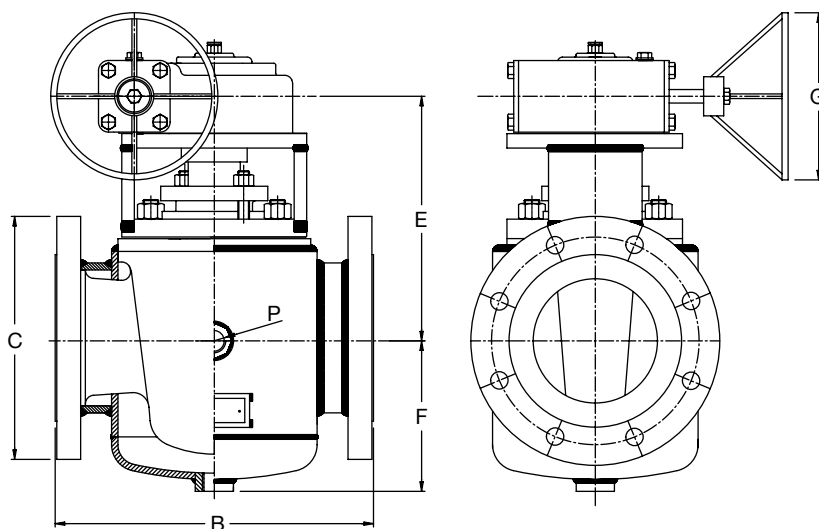

**ZRR 01R - Regular with Gear**

Size	Regular Pattern								
	NPS DN	10x12 250x300	12x14 300x350	14x16 350x400	16x18 400x450	18x20 450x500	20x24 500x600	24x26 600x650	
FACE TO FACE	<b>B</b> mm	502	762	762	838	914	991	1143	
FLANGE DIAMETER DIN PN 16	<b>C</b> mm	460	520	580	640	715	840	★	
FLANGE DIAMETER ANSI 150	<b>C</b> mm	483	533	597	635	699	813	870	
CENTER LINE TO BOTTOM OF BODY	<b>F</b> mm	380	400	445	465	525	590	675	
CENTER LINE TO CENTER OF HANDWHEEL	<b>E</b> mm	530	660	660	660	745	835	910	
HANDWHEEL DIAMETER	mm	800	1000	1000	1000	1000	1000	1000	
STEAM/INLET N. 2 HOLES N.P.T.	<b>P<sub>1</sub> or P</b> in.	3/4 - 1	3/4 - 1	3/4 - 1	3/4 - 1	3/4 - 1	3/4 - 1	3/4 - 1	
CONDENSATE OUTLET N. 1 HOLE N.P.T.	<b>P<sub>2</sub></b> in.	1	1	1	1	1	1	1	
WEIGHT	kg	360	525	690	965	1240	1480	2160	

\* **Note:** To be confirmed.



# ANSI Class 300 (PN 50)

## Full Jacketed Body

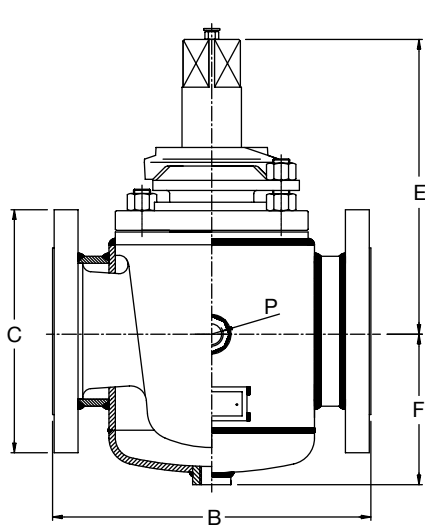

**ZRC 03R - Regular with Wrench**

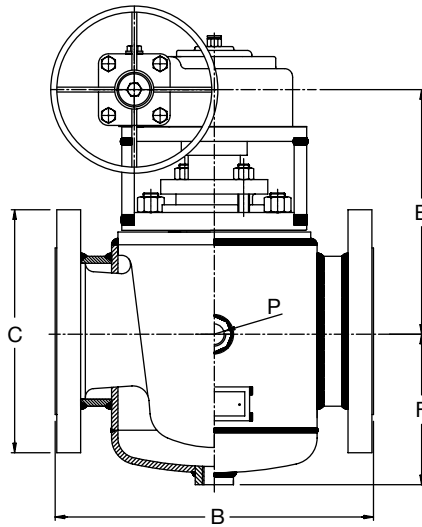

**ZRR 03R - Regular with Gear**

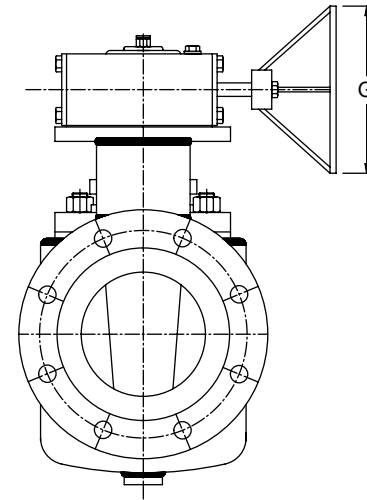

Size	Regular Pattern								
	NPS DN	1x2 25x50	1½x2½ 40x65	2x3 50x80	3x4 80x100	4x6 100x150	6x8 150x200	8x10 200x250	
FACE TO FACE	<b>B</b> mm	200	240	260	300	403	419	457	
FLANGE DIAMETER DIN PN 40	<b>C</b> mm	165	185	200	235	300	375	450	
FLANGE DIAMETER ANSI 300	<b>C</b> mm	165	191	210	254	318	381	445	
CENTER LINE TO TOP OF STEM	<b>E</b> mm	110	156	175	230	245	-	-	
CENTER LINE TO BOTTOM OF BODY	<b>F</b> mm	70	97	115	145	175	220	260	
CENTER LINE TO CENTER OF HANDWHEEL	<b>E</b> mm	-	-	-	-	-	500	615	
HANDWHEEL DIAMETER	mm	-	-	-	-	-	700	800	
STEAM/INLET N. 2 HOLES N.P.T.	<b>P<sub>1</sub> or P</b> in.	½ - ¾	¾ - 1	¾ - 1	¾ - 1	¾ - 1	¾ - 1	¾ - 1	
CONDENSATE OUTLET N. 1 HOLE N.P.T.	<b>P<sub>2</sub></b> in.	¾	1	1	1	1	1	1	
WEIGHT	kg	18	28	38	63	160	290	370	
WRENCH - LENGHT	mm	300	300	400	570	720	-	-	



# ANSI Class 300 (PN 50)

## Full Jacketed Body

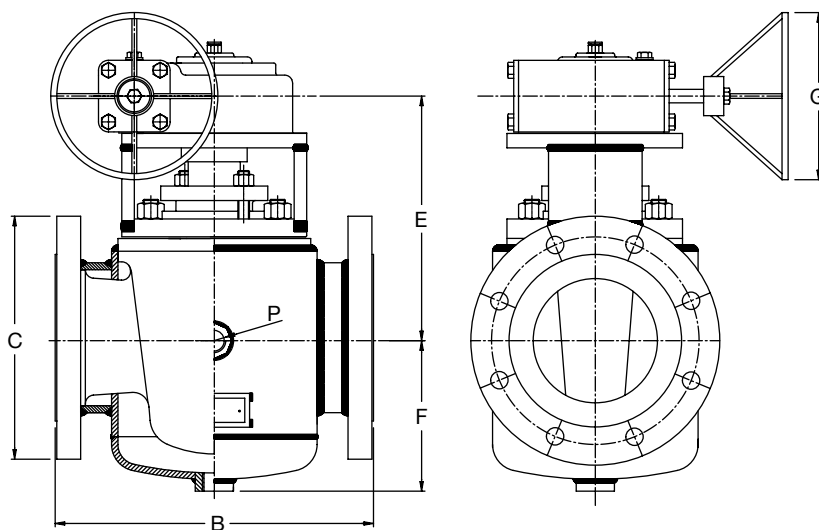

**ZRR 03R - Regular with Gear**

Size	Regular Pattern								
	NPS DN	10x12 250x300	12x14 300x350	14x16 350x400	16x18 450x500	18x20 450x500	20x24 500x600	24x26 600x650	
FACE TO FACE	<b>B</b>	mm	502	762	762	838	914	991	1143
FLANGE DIAMETER DIN PN 40	<b>C</b>	mm	515	580	660	685	755	890	★
FLANGE DIAMETER ANSI 300	<b>C</b>	mm	521	584	648	711	775	914	972
CENTER LINE TO BOTTOM OF BODY	<b>F</b>	mm	380	400	445	465	525	590	675
CENTER LINE TO CENTER OF HANDWHEEL	<b>E</b>	mm	521	660	660	660	745	835	915
HANDWHEEL DIAMETER		mm	800	800	1000	1000	1000	1000	1000
STEAM/INLET N. 2 HOLES N.P.T.	<b>P<sub>1</sub> or P</b>	in.	3/4 - 1	3/4 - 1	3/4 - 1	3/4 - 1	3/4 - 1	3/4 - 1	3/4 - 1
CONDENSATE OUTLET N. 1 HOLE N.P.T.	<b>P<sub>2</sub></b>	in.	1	1	1	1	1	1	1
WEIGHT		kg	420	570	720	985	1260	1780	2590

\* **Note:** To be confirmed.





# ANSI Class 150 (PN 20)

## Full Jacketed - Full Bore

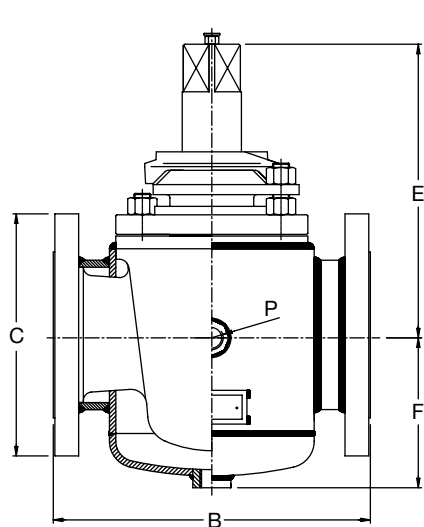

**ZFC 01R - Full with Wrench**

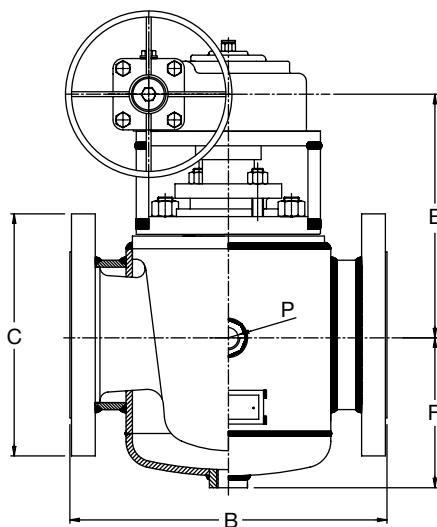

**ZFR 01R - Full with Gear**

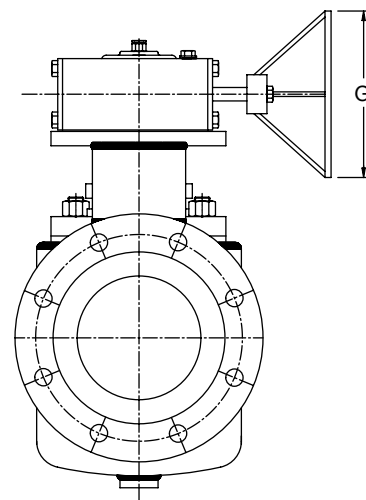

Size	NPS DN	Full Bore						
		1x2 25x50	2x3 50x80	3x4 80x100	4x6 100x150	6x8 150x200	8x10 200x250	10x12 250x300
FACE TO FACE	<b>B</b> mm	178	267	343	432	546	622	826
FLANGE DIAMETER DIN PN 16	<b>C</b> mm	165	200	220	285	340	405	460
FLANGE DIAMETER ANSI 150	<b>C</b> mm	153	191	229	280	343	406	483
CENTER LINE TO TOP OF STEM	<b>E</b> mm	110	185	205	240	-	-	-
CENTER LINE TO BOTTOM OF BODY	<b>F</b> mm	70	120	140	178	220	235	526
CENTER LINE TO CENTER OF HANDWHEEL	<b>E</b> mm	-	-	-	-	340	390	504
HANDWHEEL DIAMETER	mm	-	-	-	-	-	800	800
STEAM/INLET N. 2 HOLES N.P.T.	<b>P<sub>1</sub> or P</b> in.	1/2 - 3/4	3/4 - 1	3/4 - 1	3/4 - 1	3/4 - 1	3/4 - 1	3/4 - 1
CONDENSATE OUTLET N. 1 HOLE N.P.T.	<b>P<sub>2</sub></b> in.	3/4	1	1	1	1	1	1
WRENCH - LENGHT	mm	300	500	500	550	-	-	-



# ANSI Class 300 (PN 50)

## Full Jacketed - Full Bore

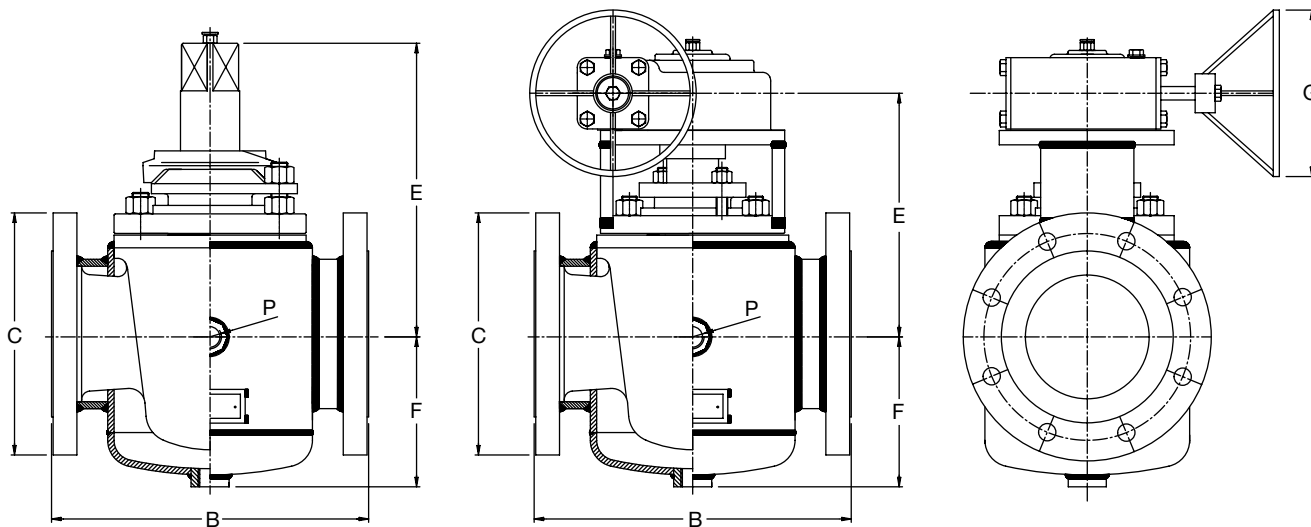

**ZFC 03R - Full with Wrench**

**ZFR 03R - Full with Gear**

Size	NPS DN	Full Bore						
		1x2 25x50	2x3 50x80	3x4 80x100	4x6 100x150	6x8 150x200	8x10 200x250	10x12 250x300
FACE TO FACE	<b>B</b> mm	191	283	387	457	559	686	826
FLANGE DIAMETER DIN PN 40	<b>C</b> mm	165	200	235	300	375	450	515
FLANGE DIAMETER ANSI 300	<b>C</b> mm	165	210	254	318	381	445	521
CENTER LINE TO TOP OF STEM	<b>E</b> mm	110	185	205	240	-	-	-
CENTER LINE TO BOTTOM OF BODY	<b>F</b> mm	70	120	140	178	220	235	526
CENTER LINE TO CENTER OF HANDWHEEL	<b>E</b> mm	-	-	-	-	340	390	504
HANDWHEEL DIAMETER	mm	-	-	-	-	-	800	800
STEAM/INLET N. 2 HOLES N.P.T.	<b>P<sub>1</sub> or P</b> in.	1/2 - 3/4	3/4 - 1	3/4 - 1	3/4 - 1	3/4 - 1	3/4 - 1	3/4 - 1
CONDENSATE OUTLET N. 1 HOLE N.P.T.	<b>P<sub>2</sub></b> in.	3/4	1	1	1	1	1	1
WRENCH - LENGHT	mm	300	500	500	550	-	-	-



## Section 3 - Multiport Three-Four Way Valves

*Multiport plug valves are built with the same characteristics such as the two way standard valves or inverted*

*plug valves. Application of multiport plug valve gives more advantages than two way valves.*

*In fact it can simplify the loop in diverting or mixing flow systems, reducing the cost of other components in the plant*

*such as flanges, pipes and fittings. Three way plug valves can be made regular and transflow pattern.*

### Regular Pattern

This design avoids mixture of the fluids in the body, in fact when the plug is turned from one position A to another B, the fluid in B starts to open as soon as the first fluid A is insulated.

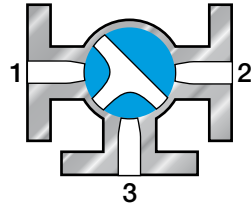

### Transflow Pattern

This design is the right solution when temporary shutt off of the flow is not allowed. Therefore when the plug is turned from one position A to another B, the fluid in B starts to open before the first one is completely insulated.

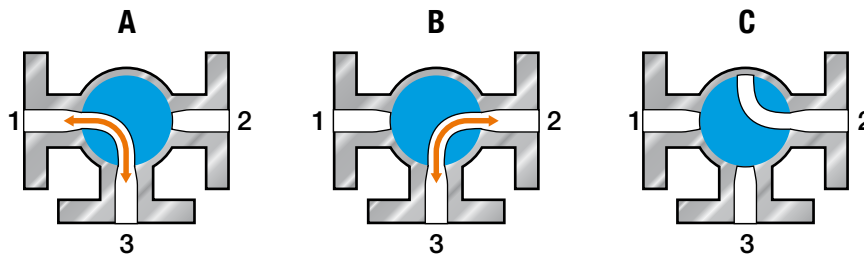
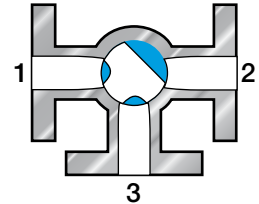

3 Way - L Ported Valves

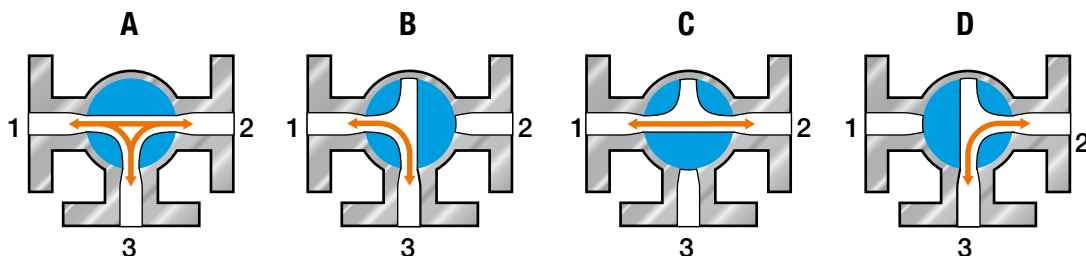

3 Way - T Ported Valves

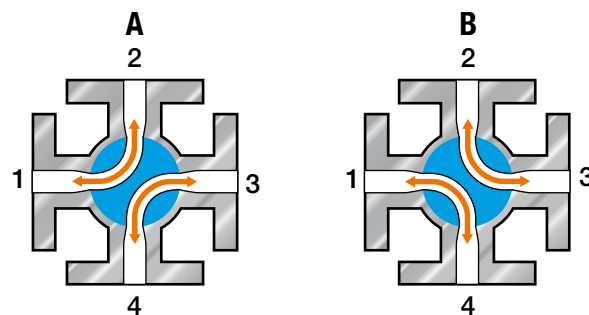

4 Way - Double Ported Valves

Four way valves can only be used as distributor,

they cannot be expected to guarantee tightness under

high differential pressure without some leakage from

one side of the valve to the other.



# ANSI Class 150 (PN 20)

## 3 and 4 Way - Type - (Transflow/Regular)

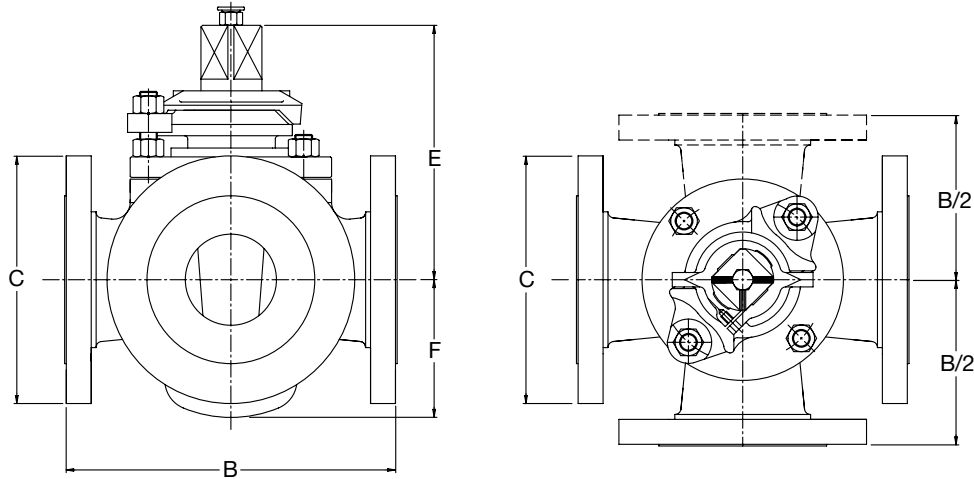

**MRC 01R - 3 way T port with Wrench**  
**LRC 01R - 3 way L port with Wrench**  
**URC 01R - 4 way with Wrench**

Size	NPS DN	Long Pattern							
		1 25	1¼ 32	1½ 40	2 50	2½ 65	3 80	4 100	5 125
FACE TO FACE	<b>B</b> mm	165	200	220	267	267	300	350	390
FLANGE DIAMETER DIN PN 16	<b>C</b> mm	115	140	150	165	185	200	220	250
FLANGE DIAMETER ANSI 150	<b>C</b> mm	108	117	127	152	178	191	229	254
CENTER LINE TO TOP OF STEM	<b>E</b> mm	140	157	177	200	230	250	265	305
CENTER LINE TO BOTTOM OF BODY	<b>F</b> mm	60	65	76	92	108	136	147	165
WEIGHT THREE WAY	kg	10	16	18	25	36	55	80	100
WEIGHT FOUR WAY	kg	14	20	22	30	42	65	95	120
WRENCH - LENGHT	mm	320	320	400	500	570	720	1010	1030





# ANSI Class 150 (PN 20)

## 3 and 4 Way - Type - (Transflow)

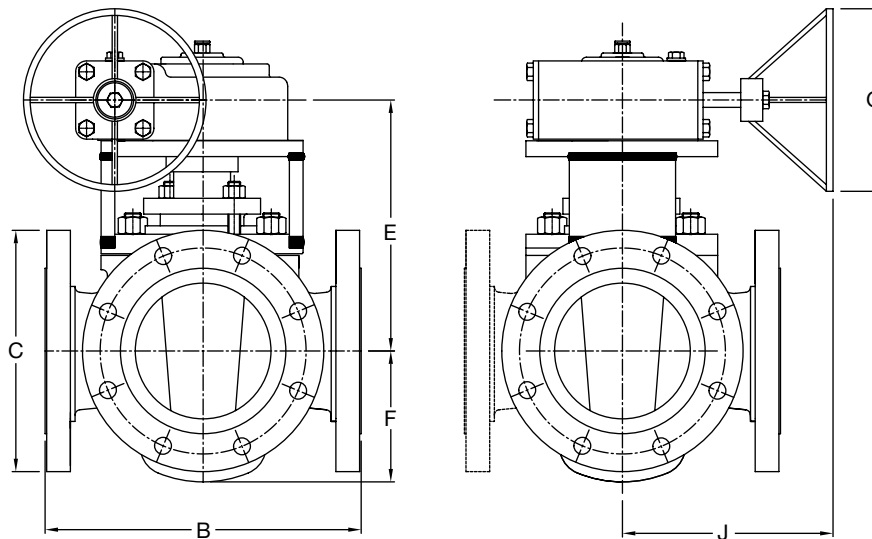

**MRR 01R - 3 way T port with Wrench**  
**LRR 01R - 3 way L port with Wrench**  
**URR 01R - 4 way with Gear (Not Shown)**

Size	NPS DN	Long Pattern			
		4 100	5 125	6 150	8 200
FACE TO FACE	<b>B</b> mm	350	413	457	508
FLANGE DIAMETER DIN PN 16	<b>C</b> mm	220	250	285	340
FLANGE DIAMETER ANSI 150	<b>C</b> mm	229	254	279	343
CENTER LINE TO CENTER OF HANDWHEEL	<b>E</b> mm	550	586	656	686
CENTER LINE TO BOTTOM OF BODY	<b>F</b> mm	147	165	215	270
HANDWHEEL DIAMETER	<b>G</b> mm	560	560	700	700
LONGITUDINAL CENTER LINE TO FACE OF HANDWHEEL	<b>J</b>	260	330	330	450
WEIGHT THREE WAY	kg	110	140	220	290
WEIGHT FOUR WAY	kg	125	160	260	320



# ANSI Class 300 (PN 50)

## 3 and 4 Way (Regular)

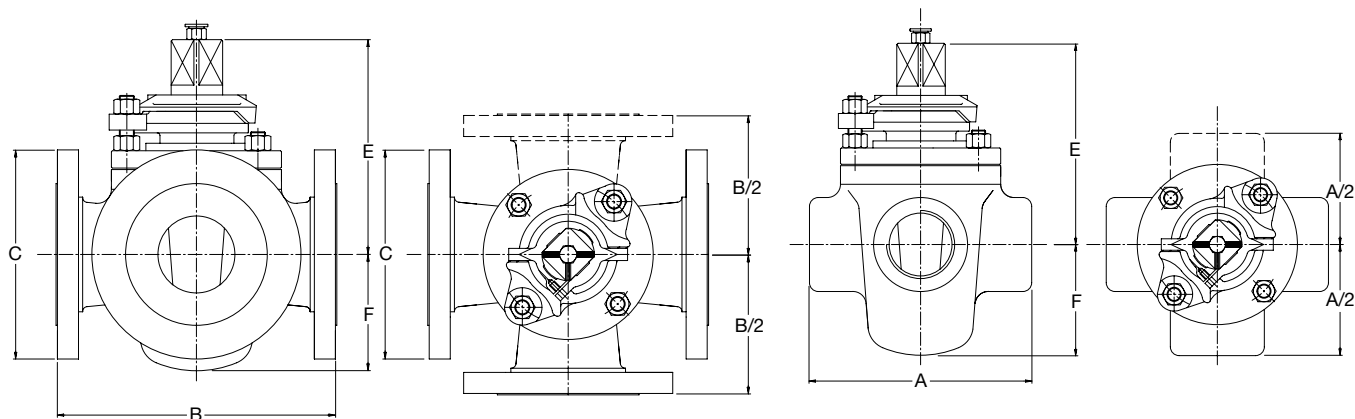

**MRC 03T - 3 way T port with Wrench**  
**LRC 03T - 3 way L port with Wrench**  
**URC 03T - 4 way with Wrench**

**MRC 03R - 3 way T port with Wrench**  
**LRC 03R - 3 way L port with Wrench**  
**URC 03R - 4 way with Wrench**

Size	NPS DN	Long Pattern							
		1/2 15	3/4 20	1 25	1 1/2 40	2 50	3 80	4 100	
FACE TO END	<b>A</b>	mm	110	110	135	145	170	-	-
FACE TO FACE	<b>B</b>	mm	150	170	190	240	283	335	410
FLANGE DIAMETER DIN PN 40	<b>C</b>	mm	95	105	115	150	165	200	235
FLANGE DIAMETER ANSI 300	<b>C</b>	mm	95	117	124	156	165	210	254
CENTER LINE TO TOP OF STEM	<b>E</b>	mm	107	107	140	177	200	243	292
CENTER LINE TO BOTTOM OF BODY	<b>F</b>	mm	42	42	60	77	92	128	150
WEIGHT 3 WAY THREADED ENDS	kg		4	4	6	15	20	-	-
WEIGHT 4 WAY THREADED ENDS	kg		4,5	5	7,5	16	22	-	-
WEIGHT 3 WAY FLANGED	kg		6,5	6	10	20	28	67	103
WEIGHT 4 WAY FLANGED	kg		-	8,5	12	24	35	82	120
WRENCH - LENGTH	mm		235	235	320	400	500	720	1010



# ANSI Class 300 (PN 50)

## 3 and 4 Way - Type - (Transflow)

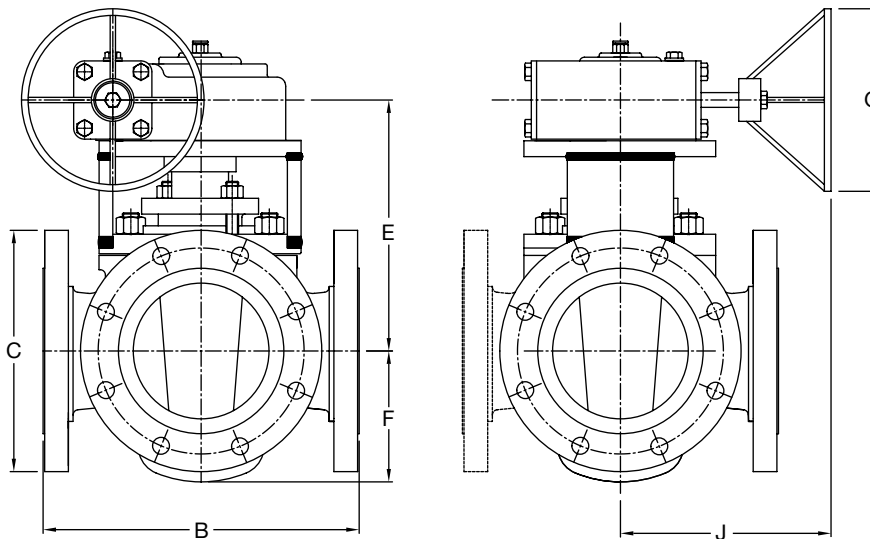

**MRR 03R - 3 way T port with Gear**  
**LRR 03R - 3 way L port with Gear**  
**URR 03R - 4 way with Gear (Not Shown)**

Size	NPS DN	Long Pattern			
		4 100	5 125	6 150	8 200
FACE TO FACE	<b>B</b> mm	410	450	502	568
FLANGE DIAMETER DIN PN 40	<b>C</b> mm	235	270	300	375
FLANGE DIAMETER ANSI 300	<b>C</b> mm	254	279	318	381
CENTER LINE TO CENTER OF HANDWHEEL	<b>E</b> mm	550	586	656	686
CENTER LINE TO BOTTOM OF BODY	<b>F</b> mm	147	165	215	270
HANDWHEEL DIAMETER	<b>G</b> mm	560	560	700	700
LONGITUDINAL CENTER LINE TO FACE OF HANDWHEEL	<b>J</b>	260	330	330	450
WEIGHT THREE WAY	kg	132	168	260	350
WEIGHT FOUR WAY	kg	150	190	312	385



# Engineering Data





## Hydrostatic-Test

Valve Rating	M.O.P.		Body Test (minimum)		Seat Test (minimum)	
	bar	lbf/in <sup>2</sup>	bar	lbf/in <sup>2</sup>	bar	lbf/in <sup>2</sup>
CLASS 125 PN 10	12,0	175	24	350	12.0	175
CLASS 150 PN 20	19.0	275	29	425	21	300
CLASS 300 PN 50	49.6	720	76	1100	55	800

## Duration of Hydrostatic Test in Minutes (minimum)

Valve Size	API 598		API 6 D	
	Shell Test	Seat Test	Shell Test	Seat Test
≤ 50 mm	≤ 2"	1/4	1/4	not applicable
50 mm to 100 mm	2" to 4"	-	-	2
65 mm to 150 mm	2 1/2" to 6"	1	1	2
150 mm to 250 mm	-	-	5	5
200 mm to 300 mm	8" to 12"	2	2	5

API 6D also requires a 5.5 bar (80 PSI) air test on the seat for same duration





## Pressure/Temperature Rating According to Asme B16.34 - 2013

**Material: ASTM A 105, ASTM A 2016 Gr.WCB, ASTM A 350 Gr. LF (Table VII - 2-1.1)**

Temperature °F (°C)	Working Pressures by Classes, psig (Bar)					
	150	300	600	900	1500	2500
-20 TO 100 (-29 to 38)	285 (20)	740 (51)	1.480 (102)	2.220 (153)	3.705 (255)	6.170 (425)
200 (93)	260 (18)	680 (47)	1.360 (94)	2.035 (140)	3.395 (234)	5.655 (390)
300 (149)	230 (16)	655 (45)	1.310 (90)	1.965 (135)	3.270 (225)	5.450 (376)
400 (204)	200 (14)	635 (44)	1.265 (87)	1.900 (131)	3.170 (219)	5.280 (364)
500 (260)	170 (12)	605 (42)	1.205 (83)	1.810 (125)	3.015 (208)	5.025 (346)
600 (316)	140 (10)	570 (39)	1.135 (78)	1.705 (118)	2.840 (196)	4.730 (326)
650 (343)	125 (9)	550 (38)	1.100 (76)	1.650 (114)	2.745 (189)	4.575 (315)
700 (371)	110 (8)	530 (37)	1.060 (73)	1.590 (110)	2.665 (184)	4.425 (305)

**Material: ASTM A 216 Gr. WCC, ASTM A 352 Gr.LCC/LC2/LC3 (Table VII - 2-1.2)**

Temperature °F (°C)	Working Pressures by Classes, psig (Bar)					
	150	300	600	900	1500	2500
-20 TO 100 (-29 to 38)	290 (20)	750 (52)	1.500 (103)	2.250 (155)	3.750 (259)	6.250 (431)
200 (93)	260 (18)	750 (52)	1.500 (103)	2.250 (155)	3.750 (259)	6.250 (431)
300 (149)	230 (16)	730 (50)	1.455 (100)	2.185 (151)	3.640 (251)	6.070 (416)
400 (204)	200 (14)	705 (49)	1.405 (97)	2.110 (145)	3.520 (243)	5.865 (404)
500 (260)	170 (12)	665 (46)	1.330 (92)	1.995 (138)	3.325 (229)	5.540 (382)
600 (316)	140 (10)	570 (42)	1.210 (83)	1.815 (125)	3.025 (209)	5.040 (348)
650 (343)	125 (9)	590 (41)	1.175 (81)	1.765 (122)	2.940 (203)	4.905 (338)
700 (371)	110 (8)	555 (38)	1.110 (77)	1.705 (118)	2.775 (191)	4.630 (305)



## Engineering Data

# Galli&Cassina Production

### Design

Galli&Cassina Plug Valves have been designed in accordance with International STD. norms. ASME B16.34 - API 599 - API 6D - API 6A - BS 5353. The stem is anti-blow-out design and incorporates three sealing system (two o-rings and one stem packing). Graphite gasket is provided to guarantee full accordance with Fire Safe API 6FA and BS 6755-Part 2 specification. Fire Safe Test Certificate is available upon request.



### Machining

Galli&Cassina's workshop machining is fully of CNC machines tools, to guarantee the maximum reliability of each designed component. Every component is designed and manufactured to conform to uniformity high standards. Coordinate measurement equipment certifies the precision of valve component to required finish tolerance.



### Assembling

Particular care is always applied at the assembling stage, to guarantee the finish product is in fully compliance with valve design.



### Testing

Valve performance are then tested in accordance with international STD norms. Every valve is pressure tested to assure the integrity of its construction before being delivered to the customer. Special testing can be designed and applied in accordance with customer's request.



### Packing

All the finished product is safely protected against any risk for damaging during the transportation by track, sea or airfreight in accordance with customer's specification.



### Shipping

Galli&Cassina shipping department is always available to deliver the goods all over the world by international forwarders (containers).





# Temperature Conversion Table

$$^{\circ}\text{C} = \frac{5}{9} (^{\circ}\text{F} - 32)$$

$$^{\circ}\text{F} = \frac{9}{5} ^{\circ}\text{C} + 32$$

$^{\circ}\text{C}$		$^{\circ}\text{F}$	$^{\circ}\text{C}$		$^{\circ}\text{F}$
-273.0	-459.4		43.3	110	230.0
-268.0	-450		46.1	115	239.0
-240.0	-400		48.9	120	248.0
-212.0	-350		54.4	130	266.0
-184.0	-300		60.0	140	284.0
-157.0	-250	-418.0	65.6	150	302.0
-129.0	-200	-328.0	71.1	160	320.0
-101.0	-150	-238.0	76.7	170	338.0
-73.0	-100	-148.0	82.2	180	356.0
-45.6	-50	-58.0	87.8	190	374.0
-42.8	-45	-49.0	93.3	200	392.0
-40.0	-40	-40.0	98.9	210	410.0
-37.2	-35	-31.0	104.4	220	428.0
-34.4	-30	22.0	110.0	230	446.0
-31.7	-25	-13.0	115.6	240	464.0
-28.9	-20	-4.0	121.0	250	482.0
-26.1	-15	5.0	149.0	300	572.0
-23.2	-10	14.0	177.0	350	662.0
-20.6	-5	23.0	204.0	400	752.0
-17.8	0	32.0	232.0	450	842.0
-15.0	5	41.0	260.0	500	932.0
-12.2	10	50.0	288.0	550	1022.0
-9.4	15	59.0	316.0	600	1112.0
-6.7	20	68.0	343.0	650	1202.0
-3.9	25	77.0	371.0	700	1292.0
-1.1	30	86.0	399.0	750	1382.0
0	32	89.6	427.0	800	1472.0
7.7	35	95.0	454.0	850	1562.0
4.4	40	104.0	482.0	900	1652.0
7.2	45	113.0	510.0	950	1742.0
10.0	50	122.0	538.0	1000	1832.0
12.8	55	131.0	566.0	1050	1922.0
15.6	60	140.0	593.0	1100	2012.0
18.3	65	149.0	621.0	1150	2102.0
21.1	70	158.0	649.0	1200	2192.0
23.9	75	167.0	677.0	1250	2282.0
26.7	80	176.0	704.0	1300	2372.0
29.4	85	185.0	732.0	1350	2462.0
32.2	90	194.0	762.0	1400	2552.0
35.0	95	203.0	788.0	1450	2642.0
37.8	100	212.0	816.0	1500	2732.0
40.6	105	221.0			

**Note:** The temperature to be converted is the figure in the blue column.  
To obtain a reading in  $^{\circ}\text{C}$  use left column; for conversion to  $^{\circ}\text{F}$  use the right column.



# Chemical and Mechanical Requirements - Cast Materials

Composition % (Maximum Percent Unless Range is Given)

	ASTM Standard (UNS designation)	Nominal Composition	C	Mn	P	S	Si
Carbon Steel	A 216 WCB (2)		0,30	1,00	0,035	0,035	0,60
	A 216 WCC (2)		0,25	1,20	0,035	0,035	0,60
	A 352 LCB (UNS J03003) (2)		0,30	1,00	0,040	0,045	0,60
	A 352 LCC (UNS J02505) (2)		0,25	1,20	0,040	0,045	0,60
	A 352 LC3 (UNS J31550)	3,5Ni	0,15	0,50-0,80	0,040	0,045	0,60
	A 487 Gr4Q 4-C	Ni-Cr-Mo	0,030	1,00	0,040	0,045	0,80
Low Alloy	A 217 WC1	C-Mo	0,25	0,50-0,80	0,040	0,045	0,60
	A 217 WC6	Cr-Mo	0,05-0,20	0,50-0,80	0,035	0,035	0,60
	A 217 WC9	Cr-Mo	0,05-0,18	0,40-0,70	0,035	0,035	0,60
	A 217 C5	Cr-Mo	0,20	0,40-0,70	0,040	0,045	0,75
	A 217 C12	Cr-Mo	0,20	0,35-0,65	0,035	0,035	1,00
Martensitic	A 217 CA15 (UNS J91150)	13Cr	0,15	1,00	0,040	0,025	1,50
	A 487 CA6NM (UNS J91540)	13Cr-4Ni	0,060	1,00	0,040	0,030	1,00
Austenitic Stainless Steel	A 351 CF3 (UNS J92500)	18Cr-8Ni	0,030	1,50	0,040	0,040	2,00
	A 351 CF3M (UNS J92800)	16Cr-12Ni-2Mo	0,030	1,50	0,040	0,040	1,50
	A 351 CF8 (UNS J92600)	18Cr-8Ni	0,080	1,50	0,040	0,040	2,00
	A 351 CF8C (UNS 92710) (1)	18Cr-10Ni-2Co	0,080	1,50	0,040	0,040	2,00
	A 351 CF8M (UNS J92900)	16Cr-12Ni-2Mo	0,080	1,50	0,040	0,040	1,50
	A 351 CN7M (UNS N08007)	29Ni-20Cr-3Cu-2Mo	0,070	1,50	0,040	0,040	1,50
	A 351 CK3MCuN (UNS J93254) (3)	20Cr-18Ni-6Mo-N	0,025	1,20	0,045	0,010	1,00
Cast Austenitic Ferritic (Duplex) Stainless Steel	A 890 CD3MN (UNS J92205)	22Cr-5Ni-Mo-N	0,030	1,50	0,040	0,020	1,00
	A 890 CE3MN (UNS J93404) (3)	25Cr-7Ni-Mo-N	0,030	1,50	0,040	0,040	1,00
	A 890 CD3MWCuN (UNS J93380)(3)	25Cr-7Ni-Mo-N	0,030	1,00	0,030	0,025	1,00

# Chemical and Mechanical Requirements Bolting Materials

Stud	A 193 B7 and B7M (5)	Cr-Mo	0,38-0,48	0,75-1,0	0,035	0,040	0,15-0,35
	A 193 B16	Cr-Mo-V	0,36-0,47	0,45-0,70	0,035	0,040	0,15-0,35
	A 193 B8M CL.2	18Cr-10Ni-2Mo	0,080	2,00	0,045	0,030	1,00
	A 320 L43	Ni-Cr-Mo	0,38-0,43	0,60-0,85	0,035	0,040	0,15-0,35
	A 320 L7 and L7M (5)	Cr-Mo	0,38-0,48	0,75-1,00	0,035	0,040	0,15-0,35
	A 453 Gr 660A		0,080	2,00	0,040	0,030	1,00
Nut	A 194 2H/2HM	C	min 0,40	1,00	0,040	0,050	0,40
	A 194 4	C-Mo	0,40-0,50	0,70-0,90	0,035	0,040	0,15-0,35
	A 194 7/7M	Cr-Mo	0,38-0,48	0,75-1,10	0,035	0,040	0,15-0,35
	A 194 8M	18Cr-10Ni-2Mo	0,080	2,00	0,045	0,030	1,00

(1) Grade CF8C shall have a columbium content of not less than 8 times the carbon content but not over 1,00%

(2) For each reduction of 0,01% below the specified maximum carbon content, and increase of 0,04% Mn above the specified maximum will be permitted up to a maximum of: 1,28% for WCB and LCB; 1,40% for WCC and LCC.



# for Body, Plug and Cover Components

## Mechanical Properties

Cr	Mo	Ni	Cu	V	W	Tensile Strength min, ksi (MPa)	Yield Strength min, ksi (MPa)	Elongation min%	Reduction of area min%
0,50	0,20	0,50	0,30	0,030	-	70 (485)	36 (250)	22	35
0,50	0,20	0,50	0,30	0,030	-	70 (485)	40 (275)	22	35
0,50	0,20	0,50	0,30	0,030	-	65 (450)	35 (240)	24	35
0,50	0,20	0,50	-	0,030	-	70 (485)	40 (275)	22	35
-	-	3,00-4,00	-	-	-	70 (485)	40 (275)	24	35
0,40-0,80	0,15-0,30	0,40-0,80	0,50	0,030	0,10	90 (620)	60 (415)	18	35
-	0,45-0,65	0,50	0,50	-	0,10	65 (450)	35 (240)	24	35
1,00-1,50	0,45-0,65	0,50	0,50	-	0,10	70 (485)	40 (275)	20	35
2,00-2,75	0,90-1,20	0,50	0,50	-	0,10	70 (485)	40 (275)	20	35
4,00-6,50	0,45-0,65	0,50	0,50	-	0,10	90 (620)	60 (415)	18	35
8,00-10,00	0,90-1,20	0,50	0,50	-	0,10	90 (620)	60 (415)	18	35
11,50-14,00	0,50	1,00	-	-	-	90 (620)	65 (450)	18	30
11,50-14,00	0,40-1,00	3,5-4,5	0,50	0,05	0,10	100 (690)	75 (515)	17	35
17,00-21,00	0,50	8,00-12,00	-	-	-	70 (485)	30 (206)	35	-
17,00-21,00	2,00-3,00	9,00-13,00	-	-	-	70 (485)	30 (206)	30	-
18,00-21,00	0,50	8,00-11,00	-	-	-	70 (485)	30 (206)	35	-
18,00-21,00	0,50	9,00-12,00	-	-	-	70 (485)	30 (206)	30	-
18,00-21,00	2,00-3,00	9,00-12,00	-	-	-	70 (485)	30 (206)	30	-
19,0-22,0	2,00-3,00	27,5-30,5	3,0-4,0	-	-	62 (425)	25 (170)	35	-
19,5-20,5	6,0-7,0	17,5-19,5	0,50-1,00	-	N=0,18-0,24	80 (550)	38 (260)	35	-
21,0-23,5	2,5-3,5	4,5-6,5	1,00	-	N=0,10-0,30	90 (620)	60 (415)	25	-
24,0-26,0	4,0-5,0	6,0-8,0	-	-	N=0,10-0,30	100 (690)	75 (515)	18	-
24,0-26,0	3,0-4,0	6,5-8,5	0,5-1,0	N=0,20-0,30	0,5-1,0	100 (690)	65 (450)	25	-
0,75-1,20	0,15-0,25	-	-	-	-	125/100 (860/690)	105/80 (720/550)	16/18	50
0,80-1,15	0,50-0,65	-	-	0,25-0,35	Al=0,015	125 (860)	105 (725)	18	50
16,0-18,0	2,00-3,00	10,0-14,0	-	-	-	100 (690)	80 (550)	(4)	45
0,70-0,90	0,20-0,30	1,65-2,00	-	-	-	125 (860)	105 (725)	16	50
0,80-1,10	0,15-0,25	-	-	-	-	125/100 (860/690)	105/80 (725/550)	16	50
13,5-16,0	1,00-1,50	24,0-27,0	-	0,10-0,50	B=0,001-0,01 Ti=1,90-2,35	130 (895)	85 (585)	15	18
-	-	-	-	-	-	--	--	-	-
-	0,20-0,30	-	-	-	-	--	--	-	-
0,75-1,20	0,15-0,25	-	-	-	-	--	--	-	-
16,0-18,0	2,00-3,00	10,0-14,0	-	-	-	--	--	-	-

(3) Pitting Resistance Equivalent Number (PREN) = Cr + 3,3Mo + 16N ≤ 40.

(4) For 3/4" (M20) and under: 110/(760), 95/(655) 15; over 3/4" (M20) up to 1" (M24): 100/(690), 80/(550), 20 over 1" M24 up to 1.25" (M30) 95/(655), 65/(450), 25 over 1.25" (M30) up to 1.5" (M36): 90/(620), 50/(345), 30.

(5) For B7M and L7M grades, a minimum carbon content of 0,28% is permitted, provided that the required tensile properties are met in the section size involved.





# Flanged-End and Welding-End Plug Valves (API 6D)

Face to Face (A) and End to End (B-C) Dimension. All Dimension in Inches.

1 Inches	Short Pattern			5 A	Regular			Venturi			Round-Port, Full Bore		
	Raised Face	Welding End	Ring and Groove		Raised Face	Welding End	Ring and Groove	Raised Face	Welding End	Ring and Groove	Raised Face	Welding End	Ring and Groove
	2 A	3 B	4 C	6 B	7 C	8 A	9 B	10 C	11 A	12 B	13 C		
<b>CLASS 150</b>													
2	7	10 <sup>1</sup> / <sub>2</sub>	7 <sup>1</sup> / <sub>2</sub>	-	-	-	-	-	10 <sup>1</sup> / <sub>2</sub>	-	11		
2 <sup>1</sup> / <sub>2</sub>	7 <sup>1</sup> / <sub>2</sub>	12	8	-	-	-	-	-	11 <sup>3</sup> / <sub>4</sub>	-	12 <sup>1</sup> / <sub>4</sub>		
3	8	13	8 <sup>1</sup> / <sub>2</sub>	-	-	-	-	-	13 <sup>1</sup> / <sub>2</sub>	-	14		
4	9	14	9 <sup>1</sup> / <sub>2</sub>	-	-	-	-	-	17	-	17 <sup>1</sup> / <sub>2</sub>		
6	10 <sup>1</sup> / <sub>2</sub>	18	11	15 <sup>1</sup> / <sub>2</sub>	-	16	-	-	21 <sup>1</sup> / <sub>2</sub>	-	22		
8	11 <sup>1</sup> / <sub>2</sub>	20 <sup>1</sup> / <sub>2</sub>	12	18	-	18 <sup>1</sup> / <sub>2</sub>	-	-	24 <sup>1</sup> / <sub>2</sub>	-	25		
10	13	22	13 <sup>1</sup> / <sub>2</sub>	21	-	21 <sup>1</sup> / <sub>2</sub>	21	22	21 <sup>1</sup> / <sub>2</sub>	26	-	26 <sup>1</sup> / <sub>2</sub>	
12	14	25	14 <sup>1</sup> / <sub>2</sub>	24	-	24 <sup>1</sup> / <sub>2</sub>	24	25	24 <sup>1</sup> / <sub>2</sub>	30	-	30 <sup>1</sup> / <sub>2</sub>	
14	-	-	-	-	-	-	27	27	27 <sup>1</sup> / <sub>2</sub>	-	-	-	
16	-	-	-	-	-	-	30	30	30 <sup>1</sup> / <sub>2</sub>	-	-	-	
18	-	-	-	-	-	-	34	34	34 <sup>1</sup> / <sub>2</sub>	-	-	-	
20	-	-	-	-	-	-	36	36	36 <sup>1</sup> / <sub>2</sub>	-	-	-	
24	-	-	-	-	-	-	42	42	42 <sup>1</sup> / <sub>2</sub>	-	-	-	
<b>CLASS 300</b>													
2	8 <sup>1</sup> / <sub>2</sub>	10 <sup>1</sup> / <sub>2</sub>	9 <sup>1</sup> / <sub>8</sub>	-	-	-	-	-	11 <sup>1</sup> / <sub>8</sub>	11 <sup>1</sup> / <sub>8</sub>	11 <sup>3</sup> / <sub>4</sub>		
2 <sup>1</sup> / <sub>2</sub>	9 <sup>1</sup> / <sub>2</sub>	12	10 <sup>1</sup> / <sub>8</sub>	-	-	-	-	-	13	13	13 <sup>5</sup> / <sub>8</sub>		
3	11 <sup>1</sup> / <sub>8</sub>	13	11 <sup>3</sup> / <sub>4</sub>	-	-	-	-	-	15 <sup>1</sup> / <sub>4</sub>	15 <sup>1</sup> / <sub>4</sub>	15 <sup>7</sup> / <sub>8</sub>		
4	12	14	12 <sup>5</sup> / <sub>8</sub>	-	-	-	-	-	18	18	18 <sup>5</sup> / <sub>8</sub>		
6	15 <sup>7</sup> / <sub>8</sub>	18	16 <sup>1</sup> / <sub>2</sub>	15 <sup>7</sup> / <sub>8</sub>	-	16 <sup>1</sup> / <sub>2</sub>	15 <sup>7</sup> / <sub>8</sub>	18	16 <sup>1</sup> / <sub>2</sub>	22	22	22 <sup>5</sup> / <sub>8</sub>	
8	16 <sup>1</sup> / <sub>2</sub>	20 <sup>1</sup> / <sub>2</sub>	17 <sup>1</sup> / <sub>8</sub>	19 <sup>3</sup> / <sub>4</sub>	-	20 <sup>3</sup> / <sub>8</sub>	16 <sup>1</sup> / <sub>2</sub>	20 <sup>1</sup> / <sub>2</sub>	17 <sup>1</sup> / <sub>8</sub>	27	27	27 <sup>5</sup> / <sub>8</sub>	
10	18	22	18 <sup>5</sup> / <sub>8</sub>	22 <sup>3</sup> / <sub>8</sub>	-	23	18	22	18 <sup>5</sup> / <sub>8</sub>	32 <sup>1</sup> / <sub>2</sub>	32 <sup>1</sup> / <sub>2</sub>	33 <sup>1</sup> / <sub>8</sub>	
12	19 <sup>3</sup> / <sub>4</sub>	25	20 <sup>3</sup> / <sub>8</sub>	-	-	-	19 <sup>3</sup> / <sub>4</sub>	25	20 <sup>3</sup> / <sub>8</sub>	38	38	38 <sup>5</sup> / <sub>8</sub>	
14	-	-	-	-	-	-	30	30	30 <sup>5</sup> / <sub>8</sub>	-	-	-	
16	-	-	-	-	-	-	33	33	33 <sup>5</sup> / <sub>8</sub>	-	-	-	
18	-	-	-	36	-	36 <sup>5</sup> / <sub>8</sub>	36	36	36 <sup>5</sup> / <sub>8</sub>	-	-	-	
20	-	-	-	39	-	39 <sup>3</sup> / <sub>4</sub>	39	39	39 <sup>3</sup> / <sub>4</sub>	-	-	-	
22	-	-	-	43	-	43 <sup>7</sup> / <sub>8</sub>	43	43	43 <sup>7</sup> / <sub>8</sub>	-	-	-	
24	-	-	-	45	-	45 <sup>7</sup> / <sub>8</sub>	45	45	45 <sup>7</sup> / <sub>8</sub>	-	-	-	
26	-	-	-	49	-	50	49	49	50	-	-	-	
28	-	-	-	53	-	54	53	53	54	-	-	-	
30	-	-	-	55	-	56	55	55	56	-	-	-	
32	-	-	-	60	-	61 <sup>1</sup> / <sub>8</sub>	60	60	61 <sup>1</sup> / <sub>8</sub>	-	-	-	
34	-	-	-	64	-	65 <sup>1</sup> / <sub>8</sub>	64	64	65 <sup>1</sup> / <sub>8</sub>	-	-	-	
36	-	-	-	68	-	69 <sup>1</sup> / <sub>8</sub>	68	68	69 <sup>1</sup> / <sub>8</sub>	-	-	-	



## Qualification of other Size Valves - API 6FA

### Size of Test Valve

NPS	DN	NPS	DN
2 API 6D 1 <sup>13</sup> / <sub>16</sub> - 2 <sup>1</sup> / <sub>16</sub> API 6A	50	2 - 2 1/2 - 3 - 4 API 6D 1 <sup>13</sup> / <sub>16</sub> - 2 <sup>1</sup> / <sub>16</sub> - 2 <sup>9</sup> / <sub>16</sub> - 3 <sup>1</sup> / <sub>8</sub> - 4 <sup>1</sup> / <sub>16</sub> API 6A	50 - 65 80 - 100
2 <sup>9</sup> / <sub>16</sub> API 6A 2 1/2 API 6D	65	2 <sup>9</sup> / <sub>16</sub> - 3 <sup>1</sup> / <sub>8</sub> - 4 <sup>1</sup> / <sub>16</sub> - 5 <sup>1</sup> / <sub>8</sub> API 6A 2 1/2 - 3 - 4 API 6D	65 - 80 100 - 125
3 API 6D 3 <sup>1</sup> / <sub>8</sub> API 6A	80	3 - 4 - 6 API 6D 3 <sup>1</sup> / <sub>8</sub> - 4 <sup>1</sup> / <sub>16</sub> - 5 <sup>1</sup> / <sub>8</sub> - 7 <sup>1</sup> / <sub>16</sub> API 6A	80 - 100 125 - 150
4 API 6D 4 <sup>1</sup> / <sub>16</sub> API 6A	100	4 - 6 - 8 API 6D 4 <sup>1</sup> / <sub>16</sub> - 5 <sup>1</sup> / <sub>8</sub> - 7 <sup>1</sup> / <sub>16</sub> API 6A	100 - 125 150 - 200
6 API 6D 7 <sup>1</sup> / <sub>16</sub> API 6A	150	6 - 8 - 10 - 12 API 6D 7 <sup>1</sup> / <sub>16</sub> - 9 - 11 API 6A	150 - 200 250 - 300
8 API 6D	200	8 - 10 - 12 - 14 - 16 API 6D 9 - 11 API 6A	200 - 250 300 - 350 - 400
10 API 6D	250	10 through 20 API 6D 11 API 6A	250 through 500
12 API 6D	300	12 through 24 API 6D	300 through 600
14 API 6D	350	14 through 28 API 6D	350 through 700
16 API 6D	400	16 and larger 24 API 6D	400 and larger

## Qualification of other Pressure Rating Valves

### Rating of Test Valve

Class	PN	Bar	Class	PN	Bar
150 API 6D	20	N/A	150 - 300 API 6D	20 - 50	N/A
300 API 6D	50	N/A	300 - 400 - 600 API 6D	50 - 64 - 110	N/A
400 API 6D	64	N/A	400 - 600 API 6D	64 - 110	N/A
600 API 6D	110	N/A	600 - 900 API 6D 2000 - 3000 API 6A	110 - 150 N/A	N/A 138 - 207
900 API 6D	150	N/A	900 - 1500 API 6D 3000 API 6A	150 - 260 N/A	N/A 207
1500 API 6D	260	N/A	1500 - 2500 API 6D 5000 API 6A	260 - 420 N/A	N/A 345
2500 API 6D	420	N/A	2500 API 6D 10000 API 6A	420 N/A	N/A 690
2000 API 6A		138	2000, 3000 API 6A 900, 1500 API 6D	N/A 150, 260	138, 207 N/A
3000 API 6A		207	3000, 5000 API 6A 1500, 2500 API 6D	N/A 260, 420	207, 345 N/A
5000 API 6A		345	5000, 10000 API 6A 2500 API 6D	N/A 420	345, 690 N/A
10000 API 6A		690	10000, 15000 20000 API 6A	N/A	690, 1034, 1379



## Lubricants

**Galli&Cassina Plug Valves can use different types of Climax lubricant grease suitable for various services.**

**The operating conditions must be specified at enquiry stage enabling us to advise which type of sealant is suitable. The lubricant grease is available as a spare part item and can be ordered as:**



- **Cartridges (suitable for hydraulic gun pump).**
  - **Drums (suitable for pneumatic pump).**
- For the selection of the correct lubricant, Galli&Cassina staff is always available at the customer's request to recommend the suitable lubricant.**

## Climax Hydraulic Gun No.1699



This specially designed, high pressure handgun, light in weight (appr. 16lbs.) is more rugged than conventional types and meets exacting demands of plug valve sealants. Built for servicing plug valves, all parts are machined with minutye accuracy.

The polished hardened steel piston is perfectly fitted in the high pressure barrel to provide absolute smoothness of operation. The CLIMAX 1699 is self-priming and can be used in any position. Because of its hydraulic principle, this gun exerts more pressure than any other portable gun.

This gun is equipped with a CLIMAX 1699 Button Head Coupler for connection to the button head sealant fitting in the shank of the valve.

This coupler has a built-in feature which locks it to fitting when the gun is under positive pressure.

The coupler cannot be connected to or separated from the fitting with the gun under pressure.

This pressure may be relieved by a turn of the by-pass valve on the gun. The by-pass valve should not be closed to a point where it is jammed into its seat, nor should it be opened tight against the stop.



The valve should be closed firmly, but no tightly. It is not necessary to open the valve past one full turn. Due to "built-in" safety features, the CLIMAX 1699

provides the maximum safety to both the valve and the gun itself. The hydraulic system of the gun is equipped with a relief fitting to protect

the gun from injury if the operator were to continue to pump after the gun had been depleted of valve sealant.

Also, to prevent damage to the valve and sealant gun, in the event of sealant clogging the system or the operator pumping too fast, a CLIMAX 15000 psi gauge is optional equipment.

This accessory indicates the point at which sufficient sealant pressure has been developed within the valve. The gauge also indicates valve adjustment and other services required.

The CLIMAX 0-15000 psi gauge is the highest quality, most reliable glycerin filled gauge available.

The one piece die cast brass case and heavy duty bourdon tube and movement enable the gauge to stand up to the shock and vibration encountered on the most demanding applications. The CLIMAX gauge also features a rubber gauge protector.

A carrying case for the CLIMAX Model 1699 is optional. Refer to the part list for available options.

**Note:** Gun shown is a 1699-S model complete with hose assembly, gauge, tee and "Z" swivel.

## Automatic Lubrication

**Galli&Cassina Plug Valves can be provided with a special automatic lubricant pump to facilitate lubrication maintenance service. The automatic pump model depends on the size of valve and its number of open/closed cycles enables**

**us to calculate the consumption of the lubricant grease during the operating service. The automatic pumps are available either electric or pneumatic motor type at the following operating temperature range: -20 to 40°C.**



# Climax Lubricants

Lubricant and No.	Type Available	Color	Temp. Range From To	Principal Services	Unsuitable For
220	Stick Bulk	Clear	-75 to 250 °F -59 to 121 °C	Very cold service for pipe lines, compressor stations, gasoline plants and crude oil production fields. For Liquid Service.	Aromatic, Solvents
262	Stick		-85 to 250 °F -65 to 121 °C	Same as above-Gas Service.	LPG
400	Stick Bulk	Red	-20 to 450 °F -29 to 232 °C	Acids and Caustics.	Liquid Hydrocarbons.
600	Stick Bulk	Tan Brown	-20 to 500 °F -29 to 260 °C	General gas and general Hydrocarbons service.	LPG
650	Stick Bulk	Blue-Green	-40 to 500 °F -40 to 260 °C	Hydrocarbon and L.P.G. service	Aromatic, Alkalies Solvents.
711	Stick Bulk	White	32 to 400 °F 0 to 204 °C	Aviation gasoline, Jet fuel, fuel blends of Alkylate.	100% Benzine
750	Stick Bulk	Black	0 to 600 °F -18 to 316 °C	Asphalt hot oil service Salt brine, high temperature steam.	Aromatic, Alkalies Solvents.
800	Stick Bulk	White	-20 to 450 °F -29 to 232 °C	Butane, Butadiene, Carbon Tetrachloride, Ethane, Propane.	Alkalies
900	Stick Bulk	Black	-20 to 650 °F -29 to 343 °C	Natural gas, petrochemical plants, rubber plants, and hot Hydrocarbons service.	Alkalies
901	Stick Bulk	Black	-30 to 300 °F -34 to 149 °C	Cold weather, Hydrocarbon lubricant.	Alkalies
950	Stick Bulk	Amber	-40 to 300 °F -40 to 149 °C	Propylenes, Benzenes Toulene, Butadiene, Xylenes, Styrene, Cumenes	Alkalies
1034-MT	Stick Bulk	Cream	-20 to 400 °F -29 to 204 °C	Liquid and gaseous. Aliphatic hydrocarbon service. (Wet or dry natural gas)	Alkalies



# Quality Assurance Program

## CERTIFICATE OF APPROVAL

This is to certify that the Occupational Health & Safety Management System of:

**Galli & Cassina S.p.A.**  
Via Drizza, 30/32  
20020 Solaro (Milano) - Italy

has been approved by Lloyd's Register Quality Assurance to the following standard:

**OHSAS 18001:2007**

The Occupational Health & Safety Management System is applicable to:

**Design & manufacturing of plug valves of the after sales services, in carbon steel and exotic special alloys with DN from 1" 3/16 to 11" up to class API 10000 P and with DN from 1" 3/16 to 11" up to class API 10000 P flow indicators and gear operators.**

Approval Certificate  
No: LRC 6017612/OHS/U/EN



## CERTIFICATE OF APPROVAL

This is to certify that the Environmental Management System of:

**Galli & Cassina S.p.A.**  
Via Drizza, 30/32  
20020 Solaro (Milano) - Italia

has been approved by Lloyd's Register Quality Assurance to the following Environmental Management System Standard:

**ISO 14001:2004**

The Environmental Management System is applicable to:

**Design & manufacturing of plug valves, including the after sales services, in carbon steel, alloy steel and exotic special alloys with DN from 1/4" up to 36" (i.e. from DN 6 to DN 900), up to class ANSI 2500 (PN 42) and with DN from 1" 3/16 to 11" up to class API 10000 P flow indicators and gear operators.**

Original Approval: 18<sup>th</sup> March 2014

Approval Certificate  
No: LRC 6017612/EMS/U/EN

## Certificate of Authority to use the Official API Monogram

License Number: 6A-0520

The American Petroleum Institute hereby grants to:

**GALLI & CASSINA S.P.A.**  
Via Drizza, 30/32  
Solaro, Milan  
Italy

## Certificate of Authority to use the Official API Monogram

License Number: 6D-0049.1

The American Petroleum Institute hereby grants to:

**GALLI & CASSINA S.P.A.**  
Via Drizza, 30/32  
Solaro, Milan  
Italy

the right to use the Official API Monogram<sup>®</sup> on manufactured products under the conditions in the official publications of the American Petroleum Institute entitled API Spec Q1<sup>®</sup> and API Spec 6D and in accordance with the provisions of the License Agreement.

In all cases where the Official API Monogram is applied, the API Monogram should be used in conjunction with this certificate number: 6D-0049.1

The American Petroleum Institute reserves the right to revoke this authorization to use the Official API Monogram for any reason satisfactory to the Board of Directors of the American Petroleum Institute.

The scope of this license includes the following product: Plug Valves  
QMS Exclusions: No Exclusions Identified as Applicable

manufactured products under the conditions in the official publications of the American Petroleum Institute entitled API Spec Q1<sup>®</sup> and API Spec 6A and in accordance with the provisions of the License Agreement.

the API Monogram should be used in conjunction with this authorization to use the Official API Monogram and in accordance with the provisions of the License Agreement.

Valves at PSL 1 through 4

American Petroleum Institute  
*John Madala*  
Director of Training and Certification Programs



## Quality Assurance System

After 95 years of manufacturing experience and latest technology, **Galli&Cassina** Quality Assurance System has been assessed, approved and certified against the following quality assurance standards: ISO 9001-2008 and API Q1. Rigorous procedures and internal audits guarantee that the Quality System is implemented at all stages, starting from incoming raw materials, production, inspection, assembly, final test, packing and shipping.

Every product is designed and manufactured to conform to uniformly high standards. These standards are assured by a quality management system which includes ISO 9001 certification and testing of all products prior to shipment. Advanced design, durable construction materials and rigid manufacturing standard provide valves you can rely on for years of trouble-free performance. Since its beginning in

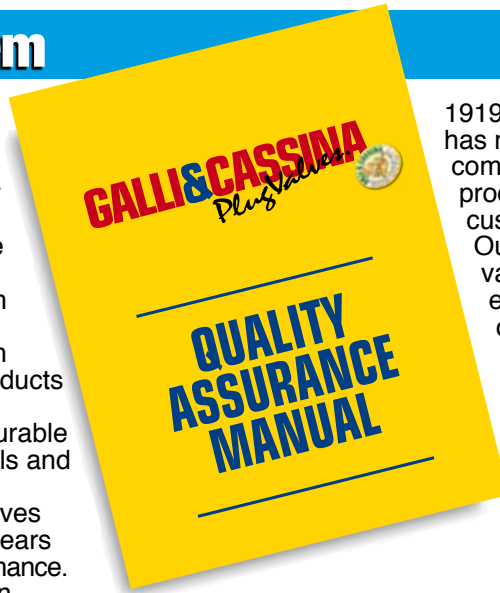

1919, **Galli&Cassina** has maintained its commitment to quality product and satisfied customers. Our focus on product variety, technical expertise and company support remains constant, from drawing board to user satisfaction, our commitment is continuous.

## Quality Assurance Development

**Galli&Cassina's** Quality Assurance System ISO 9001-2008 - HSE ISO 14001 & ISO 18001 have been assessed, approved and certified by Lloyd's Register, while the API 6D and API 6A monograms have been certified by API (American Petroleum Institute): all the certificates are the result of **Galli&Cassina's** dedication towards the aim of good reputation in the world-wide valve market, since 95 years.

In addition **Galli&Cassina** Plug Valves are in compliance with CE Pressure Equipment Directive PED N. 97/23/EC and ATEX (N. 94/9/EC) for products intended for use in potentially explosive atmospheres.



## Customer Service

**Galli&Cassina's** Customer Service is always willing to assist the customer with a prompt response to "service" requests. Full after sales services assistance can be offered either at our workshop or on site, spare parts supply. Training programs, on operation and safety.

**Cina - UAE - Kuwait  
Saudi Arabia - Europe  
India - U.S.A - Canada  
Venezuela - Colombia  
Brasil.**







## The Production Range



**Jacketed Body**

**Two Way  
Standard Type**

**Multiport Three-Four Way**

## Actuators Availability

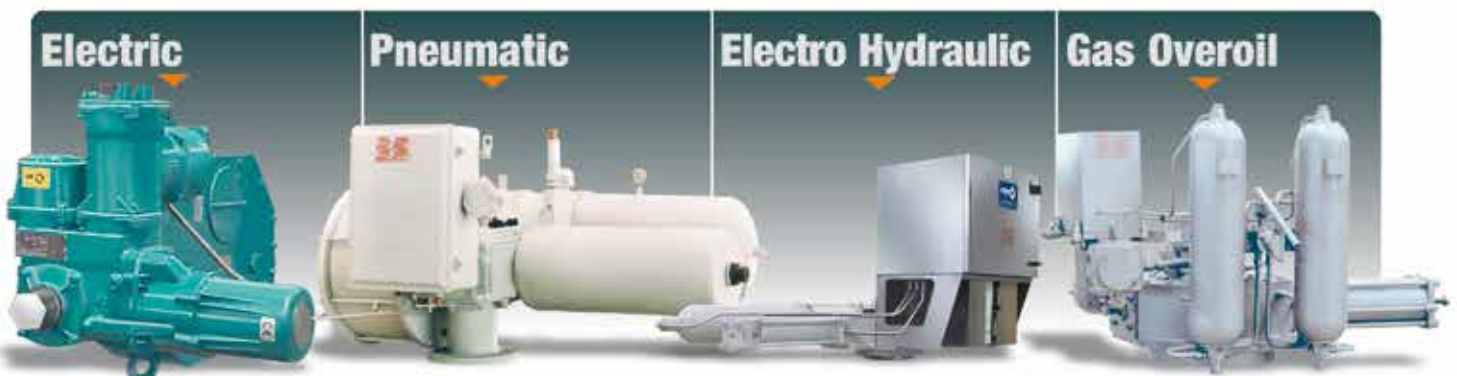

**Electric**

**Pneumatic**

**Electro Hydraulic**

**Gas Overoil**





# History

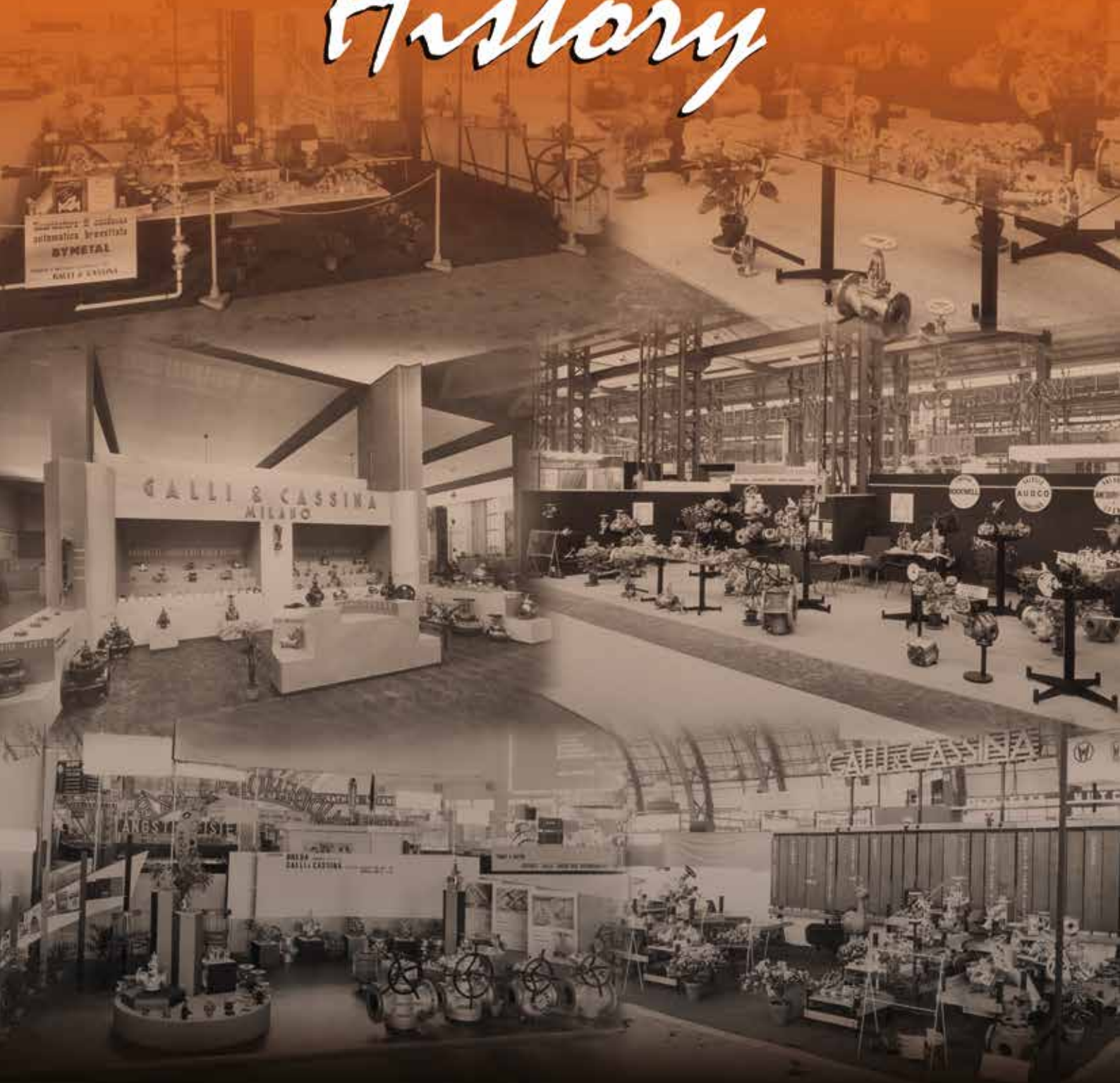

**GALLI & CASSINA**  
*Plus Valves*  
**SINCE 1919**









## **GALLI&CASSINA in the World:**

**Our products are being used in the most important Plants and Gas Pipelines all over the world.**

*Galli&Cassina Plug Valves are used in the most important hydrocarbon plants and gas pipelines all over the world.*

*For over 70 years Galli&Cassina has been committed to provide service to the end-users with a full range of products ensuring total customer's satisfaction.*

*Galli&Cassina is represented by sales offices worldwide and you are requested to contact our main office in Italy for more details.*





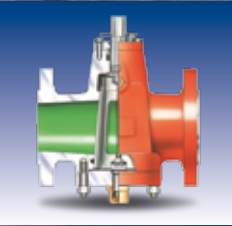
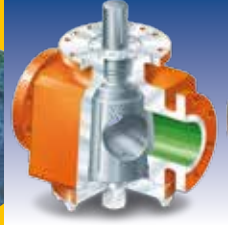
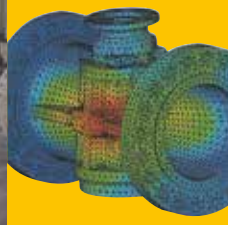

AdverTime-MI

G&C B10-2014



 **GALLI&CASSINA**  
*Plus Valves*  
SINCE 1919

**Office and Workshop:**

**GALLI&CASSINA S.p.A.**

Via Drizza, 30/32 • 20020 SOLARO (MILANO) Italy  
Phone: + 39.02.96799632/3 • Telefax: + 39.02.96799699  
<http://www.gallicassina.it> • E-mail: [valves@gallicassina.it](mailto:valves@gallicassina.it)

